

Design of Real-time Monitoring and Alarm Device for Leakage Current of Portable Insulated Rod

Xiaoyuan Liu, Zhi Xun

State Grid Shanxi Electric Power Company, Linfen Power Supply Company, Linfen, Shanxi, 041000, China

Keywords: Portable; insulated rod; leakage current; monitoring; alarm device; power grid without power outage operation

Abstract: Leakage current is an important index of insulation performance of electrical equipment. This paper introduces a portable insulation rod leakage current real-time monitoring and alarm device. Combined with the actual scenario of the insulation rod operation method, the insulation rod and current detection and alarm function are integrated. The device can effectively monitor the leakage current on the insulation rod body and give real-time alarm under abnormal circumstances, so as to ensure the safety of the power grid operation without power failure. Through the use of the device, the operator can improve the perception of the rod leakage current, take timely measures to avoid the occurrence of power grid accidents, increase the fault tolerance rate of field operations, and effectively improve the safety of the work site.

1. Introduction

Nowadays, the power system is one of the indispensable infrastructures of modern society. However, the problem of leakage current in power grid operation occurs frequently due to various reasons, such as aging equipment and adverse weather conditions. Leakage current can lead to the energy loss, apart from that, it may causes grid accidents and pose potential safety hazards to personnel and equipment. Hence, real-time monitoring of leakage current on insulated poles and taking timely measures is the key to ensure the safety of non-stop grid operation.

There are two methods for power distribution, the insulated glove and the insulated pole method, respectively. Among them, the insulated pole operation method refers to the operator and the charged body to maintain a prescribed safety distance, wearing insulating protective equipment, through the insulated pole operation mode. The insulating properties of the insulating rod is one of the most critical performance parameters of electrical equipment, when the equipment is working with electricity, personnel contact with the solid insulating cladding surface of the equipment may lead to the occurrence of personnel electrocution accidents if the abnormal situation occurs. Leakage current is generally around tens of microamps, and a microamp meter should be used to connect the detection circuit in series when measuring[1]. However, due to the insulated pole, it is easy to misjudge in the AC voltage withstand test which is affected by the environment, time, personnel, diagnostic techniques and other factors.

During the actual operation process, power operators wearing a full set of insulating protective

equipment, can not be found in a timely manner at the operating point of the line equipment sudden abnormal loss of power, usually ten minutes after the loss of power, or even longer to get the third party notification, delaying the best disposal time, resulting in the operators exposed to the risk of overvoltage injury that may occur under the risk of the window[2]. In the existing invention, the current detection and alarm device is fixed below a certain position of the working head of the insulating pole, and it is inconvenient for the staff to check the value of the meter head at a high position. In order to reduce the risk of operation, there is a need for a device that can facilitate real-time active status monitoring of the whole process of operation, and can provide the first warning in the event of a sudden and abnormal loss of power in the line equipment or damage to the insulating rod's working degree of insulation, prompting the operator to evacuate in a timely manner.

The design can be divided into two main parts: the mechanical module and the detection and alarm device. One of the biggest highlights is the addition of connecting rods to make the device removable. Staff can easily install and remove the device, which improves convenience. It is also worth mentioning that the device can be connected with Internet APP to provide more convenient monitoring and management functions. The project designed in this paper realises the detachability and intelligence of the device by introducing the linkage and internet APP design, while retaining the traditional mechanical module and detection and alarm device. This design improves the ease of use and intelligence of the equipment, besides, it also meets the needs of the staff to monitor and manage the equipment.

2. Design Ideas

2.1 Structural design

According to the requirements of GB/T878-2022 standard, for rigid insulating tools of 10kV~220kV voltage level, the leakage current of the whole tool should be no more than 0.5mA at the minimum under the specified test voltage and 1-minute test time. The design of this device is shown in Figure 1 and Figure 2.

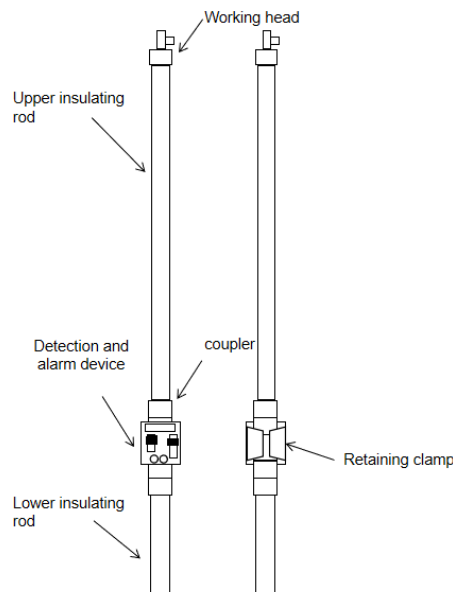

Figure 1: Schematic diagram of the insulating rod as a whole.

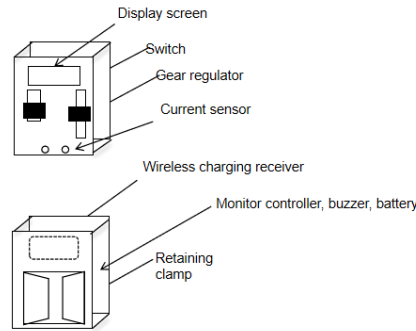

Figure 2: Leakage current detection alarm meter.

The insulating rod includes a hand-held rod, a connecting rod, a metal casing and an operating rod, which need to be set coaxially and fixedly connected in sequence. Wherein the connecting rod is an insulating material of pure quartz, one end of the metal casing is wrapped around the end portion of the handheld rod and the other end of the casing is wrapped around the low portion of the operating rod. The ends of the hand-held rod and the operating rod are connected by a connector between the ends of the connecting rod, the outer wall of the connecting casing is a detection device box, and the leakage current detection and alarm device mounting support is an insulated leakage current detection and alarm device mounting support is fitted with an operating head 0.75 m on an insulated rod, while the back side is provided with a fixing clip to fix the connecting rod. The detection device box is tightly connected to the connecting rod, and the detection device box panel is provided with an LED display, a switch, and a gear regulator, and the device box is provided with a monitoring controller, a buzzer, a battery, an LED indicator, and a Bluetooth communication module. The device box is provided with a Bluetooth communication module inside the device box, and the Bluetooth communication module, buzzer and battery are connected to the monitoring controller respectively. Moreover, a current input port is provided on the surface of the device box, a current sensor is provided inside the connection, and the current sensor is electrically connected to the monitoring controller[3].

In this design, the function of the connecting rod is critical as it is connected to the upper and lower metal sleeves. In order to achieve current blocking, a connecting rod with a higher resistivity than the insulating rod epoxy material was selected, and a pure quartz tube was specifically chosen as the connecting tube material. The resistivity of pure quartz tubing is several orders of magnitude higher than that of epoxy resin, ensuring that leakage currents can only be transmitted through the metal casing to the detection device. In addition, the current detection and alarm unit, as well as the upper and lower metal sleeves, are fitted with clips to allow easy removal of the current detection and alarm unit. The back of the unit is also fitted with a retaining clip which allows the unit to be clipped in place on a pole when in use. If not in use, the device can be dismantled, which not only facilitates carrying and transport, but also reduces damage to the device caused by external factors. Based on the design, the ease of use and protection of the device are fully considered, providing a convenient operation and use experience while ensuring the efficiency of current transmission.

2.2 Electronic design

Leakage current real-time monitoring and alarm device is a kind of intelligent device using embedded technology, wireless communication technology, etc. with the Internet of Things (IoT), which is used to solve the problems in the smart distribution network. The device consists of sensing module, detection module, alarm module and communication module.

The sensing module is connected to the metal housing and is used to detect small leakage currents

in the insulating rod. The detection module converts the weak current signal into a measurable voltage signal using the I/V conversion principle, which is measured and displayed. The device displays the current leakage current in the meter head and compares it with a preset threshold value via the main system. When the leakage current of an insulated pole body exceeds the safety threshold, the device triggers the internal control oscillator to output a rectangular wave signal, as well as triggering a buzzer and neon light to give a warning. This provides a timely warning to the operator to ensure work safety.

The communication module can be connected to a mobile phone application (APP), which is convenient for staff to view via mobile phone. Through the Internet APP on the mobile phone or computer, the status of the equipment can be monitored in real time, including the current leakage current size, alarm threshold and other parameters. At the same time, the APP also provides an alarm function, so that once abnormalities are detected, the staff can receive alarm notifications in time so that appropriate measures can be taken. This internet-based design not only improves the intelligence of the equipment, but also makes it easier to monitor and manage the equipment. This is of great importance in situations where insulated poles are too long or not easily viewed. Through the use of real-time leakage current monitoring and alarm devices, the leakage current of insulated poles can be grasped in a timely manner, reducing safety hazards and ensuring the normal operation of power equipment. In addition, a very simple and convenient wireless charging module is also designed for the current detection and alarm device, which can be charged by simply placing the device on the wireless charging coil when not in use. The design of the device is shown in Figure 3.

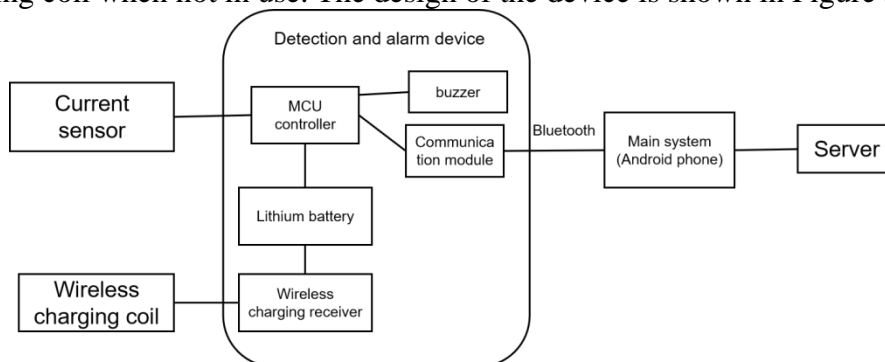

Figure 3: Current detection alarm device design.

With the development and maturity of localised chips, the controller chooses ESP32-WROOM-32E series, and the built-in chip is ESP32-D0WD-V3 in the ESP32 series, which is highly integrated with Wi-Fi and Bluetooth system chips for IoT applications. On one hand, the two CPU cores can be controlled individually and the CPU clock frequency can be adjusted from 80MHz to 240MHz, which allows users to turn off the power of the CPU and use the low-power co-processor to monitor peripheral status changes or whether certain analogue quantities are over the threshold; on the other hand, it has a 2.4GHz dual-mode WiFi and Bluetooth chip, which allows it to connect the detected current data via Bluetooth to the mobile phone application (APP). The application programme (APP) is used to communicate with the cloud platform and display the current leakage current data of the insulated poles [4]. On the APP, alarm thresholds can be set, historical data can be viewed, and real-time alarm notifications can be received. By connecting to the Internet APP, the staff can achieve remote monitoring and management of the insulated pole leakage current alarm device, which improves work efficiency and safety. At the same time, data can be recorded and statistical reports can be generated to provide more useful information and reference for equipment maintenance and troubleshooting.

3. Operation method

Staff members use insulated poles to carry out electrified work in accordance with normal procedures. The device will detect the magnitude of the leakage current of the pole in real time, and once it exceeds the set threshold, it will immediately issue an alarm to remind the staff to pay attention to safety. In order to let the staff keep track of the situation at anytime and anywhere, the device also supports Bluetooth connection to mobile phone APP, through which the staff can conveniently check the real-time leakage current data and receive alarm notifications in a timely manner. This means that the staff can arrange their working time more flexibly and deal with emergencies in a more timely manner. And the flow of the insulated pole work method for power-carrying operation is shown in Figure 4.

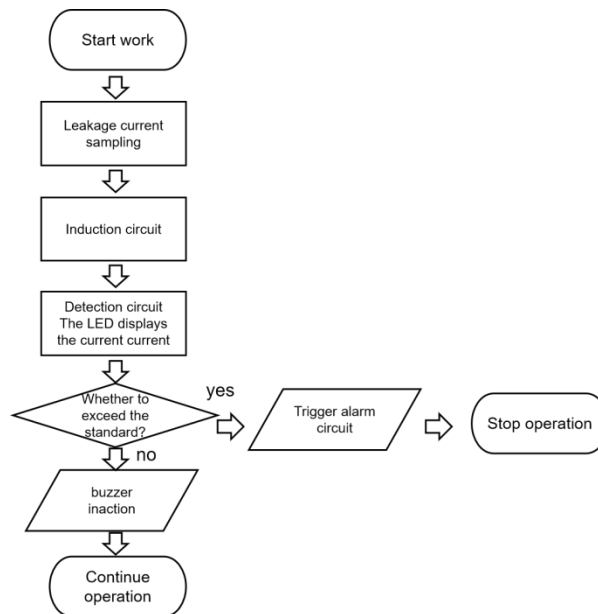

Figure 4: Flow of insulated pole work method for electric operation.

4. Device advantages

The advantages of portable insulated pole leakage current real-time monitoring and alarm device in the non-stop operation of power grid are shown as follows:

(1) Real-time monitoring capability: Functional integration of the insulated pole and current detection alarm allows real-time monitoring of the leakage current on the insulated pole. By sensing the current signal through the sensor and transmitting it to the data acquisition unit, the operator can know the current leakage current situation at any time.

(2) Improved safety: By monitoring the leakage current on the poles, the device can quickly detect abnormalities and send real-time alarm messages to the operator through the alarm system. In this way, the operator can take timely measures to avoid grid accidents and improve work safety.

(3) Portability: the resistivity of quartz connecting rod is much higher than that of insulating rod material, which has the effect of isolating the current; the upper and lower rods of insulating rod and quartz connecting rod are connected by a metal ring, and the detecting and alarming devices are connected to the positive and negative poles of the metal ring, which makes the device convenient and can be disassembled at any time. Portable design makes the monitoring and alarm device easy to carry and use. Operators can easily carry the device to different work sites and monitor it at any time, flexibly responding to different scenarios.

(4) Visibility: Increase the communication module and connect the mobile phone application via

Bluetooth to solve the problem of inconveniently viewing the leakage current size of the equipment meter head due to the long insulated pole; the mobile phone application not only supports viewing the value, but also sets the alarm threshold, views the historical data, and receives the real-time alarm notification and other multi-functional applications.

(5) High sensitivity: The equipment is highly sensitive and can accurately sense weak leakage current signals on insulated bars. Even if the leakage current is very small, the equipment can issue an alarm in time, allowing the operator to avoid potential safety risks.

(6) Rapid response and processing: the alarm system of the equipment can respond quickly to abnormal situations and send alarm information to the operator in time. The operator can immediately take corresponding measures to prevent further expansion of the accident and safeguard the continuity of non-stop operation of the power grid.

(7) Improve work efficiency: Through real-time monitoring and timely alarm, the portable insulated pole leakage current real-time monitoring and alarm device can help operators better manage the leakage current problem on insulated poles, shorten the response time and improve the overall work efficiency.

In short, the advantages of this device make it a must-have. Its portability, high sensitivity and fast response make it an important breakthrough in the field of leakage current detection. By using this device, we can improve detection efficiency, reduce costs and ensure staff safety. The device will play an important role in the non-stop operation of the power grid to ensure the normal operation of the power grid and the safety of personnel[5].

5. Prospects and Challenges

Portable insulated pole leakage current real-time monitoring and alarm device is an effective technical means to improve the safety of non-stop operation of the power grid. The device is expected to be more widely used in the future power system, which will bring a lot of convenience to the non-stop operation of the power grid. However, there are some technical and economic challenges in practical application. One of them is the sensitivity of the sensor. The sensitivity of the sensor in monitoring the leakage current of insulated poles is critical to the accuracy of the device. Therefore, future research could focus on improving the design of the sensor and increasing its sensitivity to ensure that the device can accurately monitor leakage current.

Next is the cost of the device. Although the advantages of the portable insulated pole leakage current real-time monitoring and alarm device are obvious, the high cost has become a major limitation to its application. In order to promote the application of the device more widely, we should look for ways to reduce the cost, such as using more economical and practical materials and simplifying the structure of the device[6]. By reducing the cost, more power systems can be benefited and the safety of non-stop operation of the whole power grid can be improved.

In addition to technical and economic challenges, improving the adaptability of equipment is also a concern. Different power systems may have different environments and conditions, which place higher demands on the adaptability of the equipment. Future research could focus on improving the adaptability of the equipment to ensure that it can be widely used in different power systems and maintain its stability and reliability in different environments.

6. Conclusion

In this paper, we propose a portable insulated pole leakage current real-time monitoring and alarm device, which integrates the insulated pole and current detection and alarm functions with each other, and is able to effectively monitor the leakage current on the insulated pole to ensure the safe operation of the grid without power. The portable insulated pole leakage current real-time monitoring and alarm

device has great potential and advantages in the non-stop operation of power grid. Through the research on improving the sensitivity of the sensor, reducing the cost, and improving the adaptability of the device, it is expected to further promote the application of this technology and make a greater contribution to the safe operation of the power system.

References

- [1] FANG Kaijie, JING Zhiqi, LI Zhuoqing, et al. Research on Leakage Current Measuring Device for Withstand Voltage Test [J]. *Electric Drive Automation*, 2023, 45(04): 37-40.
- [2] LIU Xinyu. Design of Non-electric Alarm Device for Insulating Pole Operation Method [J]. *Electric Engineering*, 2022, (07): 74-78.
- [3] LU Enqing, HUANG Caiping, SHI Yuliang, et al. Development of a new type of electric wire-cutting tool set for insulated poles for power-carrying work[J]. *Science and Technology & Innovation*, 2022, (19): 20-25.
- [4] WEN Hongwu, CHEN Danhong, XIE Xiaohua, et al. A Study on the Design of the Insulated Telescopic Clamp-Type Current Measuring System [J]. *Journal of Chongqing Electric Power College*, 2023, 28(02): 14-18.
- [5] DI Meihua, HU Min, LIU Chen, et al. Development of Insulating Pole Type Arc Suppression Switch [J]. *Rural Electrification*, 2022, (12): 51-54.
- [6] XIANG Wenxiang, LIU Kai, WU Zhengrong. Flexible Insulating Rod for Live Line Working with Ultra-High Voltage [J]. *Electric Power*, 2014, 47(05): 78-82.