

# *The Processing Method of CNC Lathe Processing Technology for Complex Parts*

**Hengqiang Liao**

*Guangdong Huali Technician College, Guangzhou, 511399, China*

**Keywords:** Machining Process; Tool Path; Cutting Amount; Size Calculation

**Abstract:** Process processing is a complex and very important step in the machining process of CNC lathes, closely related to the compilation of machining programs, the quality and effectiveness of part machining. Process processing includes analyzing part drawings, calculating coordinate point dimensions, determining the cutting tools of CNC lathes, requirements for tool installation, formulating machining plans, and determining cutting quantities.

To master the process processing of CNC lathe machining, it is not only necessary to master the process regulations and cutting knowledge of ordinary lathe machining, but also to have a solid basic knowledge of machining technology. It is necessary to have a comprehensive understanding of various aspects of formulating process plans in CNC lathe machining.

## **1. Analyze part drawings**

Check for defects in the geometric conditions that make up the machining contour.

Due to various reasons such as part drawing design or drawing, there may be insufficient data that constitutes the machining contour on the drawing, or the given geometric conditions may be unreasonable, resulting in difficulties in mathematical processing and contradictions in the given geometric conditions, blurred dimensions, or blurry positions and closed dimensions on the drawing. This will increase the difficulty of programming, sometimes even making it impossible to program, or due to unclear drawing conditions, resulting in machining errors, Causing unnecessary losses by scrapping parts.[1]

## **2. Coordinate point size calculation**

In the numerical calculation work of manual programming, except for the complex and cumbersome fitting calculations and error analysis calculations required for the node coordinate support of non circular curves, all other calculations are relatively simple. Usually, the calculation can be carried out with the help of trigonometric functions. Generally, similar triangles and plane analysis methods of trigonometric functions are used. Below, taking Figure 1 as an example, we will introduce the coordinate zero point as the right end face. The dimensions of points A, B, C, D, E, F, G, H are calculated by using the taper formula:  $C=(D-d)/L$  deduces  $d=D-CL=34-1/5 * 10=32$ , so the coordinates of point H are X32 Z-10, the coordinates of point A are X52 Z-6.51, the dimensions of

point E are calculated by using the circular equation and the inverse trigonometric function method to obtain X52 Z-28.34, the coordinates of point B, C and D are calculated by using similar triangles, the coordinates of point B are X48 Z-9.34, and the coordinates of point C are X48 Z-20.66, The coordinates of point F and point G are calculated using a similar triangle to obtain the coordinates of point F as X34.46 z-70 and point G as x32 Z-67.51. This will determine the coordinates to be calculated.

In the formula: C - taper L - cone length, mm.

D - Small end diameter, mm D - Large end diameter, mm.

### **3. Selection of cutting tools for CNC lathes**

In the processing of CNC lathes, product quality and labor productivity are to a considerable extent constrained by cutting tools. Although the pre-cutting principle of turning tools is basically the same as that of ordinary lathes, due to the requirements of the machining characteristics of CNC lathes, the selection of cutting tools, especially the geometric parameters of the pre-cutting part, requires special treatment of the shape of the cutting tools in order to meet the machining requirements of CNC lathes and fully utilize the benefits of CNC lathes, Taking Figure 1 as an example, the selection of CNC lathe tools is described below:

#### **3.1. Tool material**

##### **3.1.1. High speed steel cutting tools**

High speed steel cutting tools are easy to manufacture, easy to grind, and easy to obtain sharp edges. Moreover, it has good toughness and can withstand large impact forces, making it particularly suitable for manufacturing various complex forming and hole processing tools. However, high-speed steel has poor heat resistance, with a heat resistance temperature of around 600 °C and a hardness of HRC62 to 66, indicating thermal deformation strength 6. The  $\sigma_b$  is about 3430MPa, so it is not suitable for high-speed and strong cutting.

##### **3.1.2. Hard alloy**

There are three types of commonly used hard alloys: P, M, and K. Class P is suitable for processing black metals with long or short chips, Class M is suitable for processing black metals and non-ferrous metals with long or short chips, and Class K is suitable for processing black metals, non-ferrous metals, and non-metallic materials with short chips. The room temperature hardness reaches HRA89-94, the heat resistance temperature reaches 800 to 1000 °C, and the cutting speed can reach about 220m/min during cutting, So hard alloy is currently the most widely used material for turning tools.

##### **3.1.3. Coated cutting tool**

The durability of coated hard alloy blades can be increased by 1-3 times, while the durability of coated high-speed steel tools can be increased by 2-10 times.

##### **3.1.4. Non-metallic material cutting tools**

The non-metallic materials used for cutting tools mainly include ceramics, diamonds, and cubic boron nitride, but these cutting tool materials are more expensive and suitable for competitions.

## 3.2. Tool type

The commonly used tool types for CNC lathes include pointed turning tools, formed turning tools, standardized tools (indexable turning tools), and special shaped turning tools.

### 3.2.1. Pointed turning tool

This type of turning tool consists of main and auxiliary cutting edges, such as 90 ° inner and outer circular turning tools.

### 3.2.2. Formed turning tool

The commonly used forming turning tools for CNC lathes include thread cutting tools and small semi circular arc turning tools.

### 3.2.3. Standardized tools (indexable turning tools)

The blades of this type of turning tool have become standardized, with high positioning accuracy and saving tool setting time, so they are widely used in CNC lathes.

## 3.3. Selection of cutting tools

The material is made of 45 # steel, and the selection of cutting tools requires high strength, reliability, and durability. Therefore, it is better to choose hard alloy cutting tools with YW coating.

## 3.4. Using standardized tools

In order to adapt to the processing of CNC lathes, reduce auxiliary time, and continuously improve the quality and production efficiency of the workpiece, as shown in Figure 1, the workpiece has a conical shape, and the surface of concave and convex arcs needs to be machined. Therefore, a standardized and indexable hard alloy YW type tool with a tool tip angle of 35 degrees, a main deviation angle of 90 degrees, a back angle of 8 degrees, a front angle of 15 degrees, and a blade inclination angle of 0 degrees is selected. The blade shape is as follows:

Turning and cutting tools with a sharp angle of 60 degrees and a front angle of 0 degrees for external thread cutters all use YT15 type hard alloy cutting tools, as YT15 type hard alloy is suitable for processing various types of steel.

Select YW1 type hard alloy cutting tools with a main deviation angle of 90 degrees, a back angle of 8 degrees, a front angle of 15 degrees, and a blade inclination angle of 0 degrees for internal hole processing.

High speed steel turning tools with a front angle of 10 °; a main back angle of 9 °; a secondary back angle of 3 °; and a sharp angle of 30 degrees for machining internal trapezoidal threads are also high-speed steel turning tools.

## 4. Requirements for tool installation

As shown in Figure 1, both the inner and outer surfaces of the workpiece have taper machining, so the tool tips for machining the outer circle and the inner hole must be strictly aligned with the axis of the workpiece.

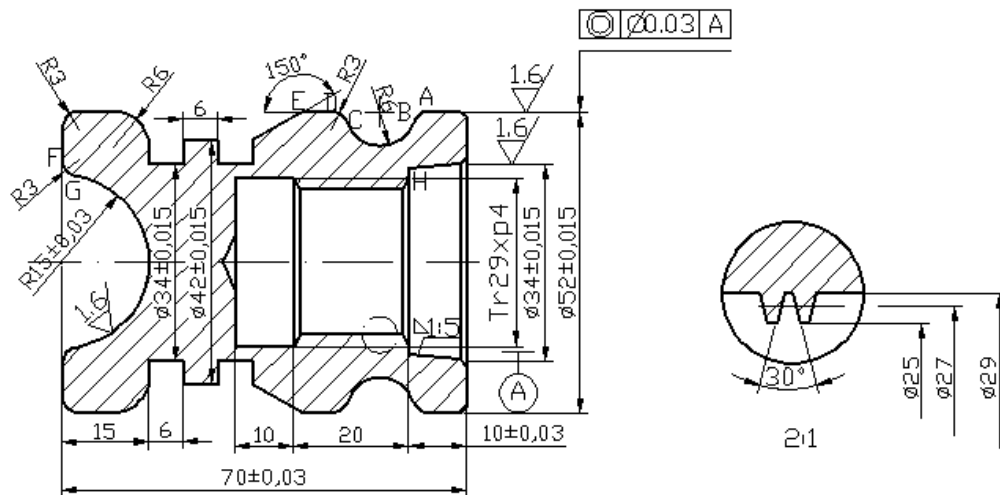

Figure 1: Undeclared chamfer undeclared chamfer 1x45 °

## 5. Develop processing plans

The machining plan of a CNC lathe includes the formulation of processes, steps, and tool paths. Taking the workpiece diagram shown in Figure 1 as an example, the machining plan of a CNC lathe is introduced. Due to the complex machining shape of the outer contour and the need for inner holes to be machined.

Machining coordinate zero point:

X: Axis;

Z: Right end face of the workpiece;

Process analysis: Due to the complex shape of the processed workpiece and the large machining allowance, it is necessary to arrange rough machining and precision machining during processing.

### 5.1. Coarse before refined

In turning processing, the rough machining process should be arranged first, and the machining allowance of the blank should be removed in a short period of time to improve production efficiency. At the same time, the uniformity of the allowance for precision machining should be met as much as possible.

### 5.2. Near before far

In general, in the processing of CNC lathes, the parts close to the starting point of the tool are usually arranged to be processed first, and the parts far from the starting point of the tool are processed later. This can shorten the tool movement distance, reduce the number of idle tool passes, improve efficiency, and also ensure the rigidity of the workpiece and improve its cutting conditions.

### 5.3. First in, then out

When processing parts with both inner and outer surfaces, it is usually necessary to arrange the processing of the inner surface before processing the outer surface. This is because a drill bit is used to drill holes before processing the inner hole. The cutting depth and cutting force during drilling are large. Moreover, the machining of the inner surface is affected by poor tool rigidity, which increases

its vibration and makes it difficult to control the dimensional accuracy and surface shape accuracy of the inner surface. If the outer surface is machined before processing the inner surface. At this point, the rigidity of the workpiece is poor, and the rigidity of the inner hole cutter bar is insufficient, making it difficult to process and remove chips. When machining holes, the dimensional accuracy and surface roughness of the holes are not easily guaranteed, so the inner hole should be machined first before the outer surface.

So the processing steps are as follows:

- (1) Clamp the blank workpiece and extend it out about 80mm long, turning the right end face;
- (2) Using  $\phi$  Drill with a 23mm drill bit at a depth of 76mm.
- (3) Use the G71 rough machining cycle command to rough machine the internal taper of 1:5 and  $\phi$  25 inner holes, and then use G70 finishing cycle command to finish machining 1:5 inner taper  $\phi$  25 inner hole.
- (4) Rough and fine machining of internal trapezoidal threads using the G76 instruction.
- (5) Rough machining with G71 instruction  $\phi$  Finish machining with G70 instruction after 48 outer circles
- (6) Use the G73 command to rough machine the arcs of R6 and two R3, and then use the G70 command to fine machine the arcs of R6 and two R3.
- (7) Rough machining 30° outer taper with G73 instruction  $\phi$  After finishing the outer circle of 42, use the G70 command.
- (8) Use the G72 command to rough and finish machining the R6 outer arc, and then use the G70 command to finish machining.
- (9) Cut two 6x using a cutting knife with a width of 3mm  $\phi$  The groove of 34 and the outer arc of R3 are cut to a total length of 70mm.
- (10) Turn around and clamp for correction, rough machining the arcs of R15 and R3 using the G73 command, and then fine machining the arcs of R15 and R3 using the G70 command.

Taking Figure 1 as an example, the specific processing program is as follows:

The procedure for machining the outer surface is as follows:

```
O0011
G50 X150 Z50 / M03 S500 T0101/ G90 X53 Z-75 F160
X52 F160 S1600/ G00 X150 Z50/ T0101/G00 X53 Z-6.51
G73 U5 R0.005/ G73 P1 Q2 U0.8 F150 S500
N1 G01 X52/ G03 X48 Z-9.34 R3/ G02 X48 Z-20.66 R10
N2 G03 X52 Z-23.49 R3/ G70 P1 Q2 F160 S1500
G00 X53 Z-28.34
G73 U3 R0.003/ G73 P3Q4 U0.8 F500 S150
N3 G01 X52/ X42 Z-37/ Z-55/N4 X52/ G70 P3 Q4 F160 S1500
G00 X150 Z50/ T0202(Cutting knife, Knife width is 3mm)
G00 X53 Z-37/ G01 X34 F40/ G00 X53/ W-3/G01 X34 F40
G00 X53/ Z-47/ G01 X34 F40/ G00 X53
G72 W2 R0.5/ G72 P5 Q6 U0.5 W0.2 F40
N5 G00 Z-61/ G01 X52/ G02 X40 W6 R6/ G01 X34/ N6 Z-47
G70 P5 Q6 F40
G00 X53/ Z-70/ G01 X64F40/ G00 X53/ Z-67/ G01 X52 F40
G01 X50 F40/ G03 X64 Z-70 R3/ G01 X0 F40/ G00 X150/ Z50/T0100
M05/ M30
```

Turn around and clamp  $\phi$  52 outer circle correction, machining R15 and R3 inner arcs, the program is as follows:

```
O0012
G50 X150 Z50/ M03 S450T0101/ G00 X10 Z5
```

G73 U-5 W5 R0.005/ G73 P1 Q2 U-0.5 W0.3 F120 S500  
N1 G00 X34.46 S1600/ G01 Z0/ G03 X29.58Z-2.49 R3  
N2 G02 X0 Z-15 R15/ G70 P1 Q2 F1600  
G00 X150 Z50/ T0100/ M05/ M30

## 6. Determine the cutting amount [2]

The cutting amount includes three parts: cutting speed, cutting depth, and feed rate. The calculation formula is as follows:

$$V = \pi Dn/1000$$

V - cutting speed unit: m/min

D - workpiece diameter unit: mm

N - Speed unit: r/min

$$A_p = (D-d)/2$$

A<sub>p</sub> - cutting depth unit: mm

D -- Surface to be machined Unit: mm

D - Machined surface unit: mm

(1) In rough turning, the selection of cutting parameters, increase of cutting speed, feed rate and cutting depth can improve productivity, but the cutting depth  $a_p$  has the smallest impact on tool life, followed by feed rate F, and the largest impact is cutting speed V. This is because the cutting speed has the largest impact on cutting temperature, high temperature, accelerated tool wear, and significantly reduced tool life, Therefore, the reasonable selection of rough turning cutting amount should choose a cutting depth of  $a_p=3\text{mm}$  as much as possible, followed by a larger feed rate of  $F=120\text{mm/min}$ , and finally based on the selected  $a_p$  and F, and in the process system rigidity. Choose a reasonable cutting speed  $V=15\text{-}30\text{m/min}$  under the conditions of tool life and machine power permission.

(2) Selection of cutting parameters during precision machining. When precision machining, the cutting depth is small and the cutting force generated is not significant. The main considerations are surface roughness and dimensional accuracy. To suppress the generation of chip deposits and improve the surface quality of the workpiece, hard alloy turning tools are used for precision machining. Usually, higher cutting speeds ( $V>80\text{m/min}$ ) are used for precision turning with high-speed steel turning tools, and lower cutting speeds ( $V<5\text{m/min}$ ) are used.

## 7. Conclusion

Due to the rapid development of CNC lathes and the variety of process processing methods, different parts have different process methods. It is good to ensure the quality of the workpiece while completing the processing process in the shortest possible time. Therefore, it is necessary to summarize in practical operation to choose the best process processing method.

## References

- [1] Song X, Zhang M, editor in chief, "Programming and operation of CNC lathes", Guangdong Economic Publishing House 2006; 107-108.  
[2] Liu Yayi. Research on CNC Lathe Processing Technology for Complex Parts. Enterprise Technology Development Monthly, 2016, 35 (22)