

Design of a Remote Video Communication Transmission Control System

Yujing Zhang

China Mobile Group Inner Mongolia Co., Ltd., Hohhot, China

Keywords: Remote transmission, video communication, transmission control, system design

Abstract: This paper designs a wireless video transmission scheme based on WIFI technology. Proceeding from the actual functional requirements, the system design was completed using WIFI technology and embedded technology. Specifically, the integrated Cortex-M3 core minimum system board STM32F103C8T6, ESP32WiFi chip and CMOS OV2640 camera module launched by Espressif Lexin Information Technology were adopted for software and hardware planning and design, and the remote video transmission system test analysis was completed; Using AltiumDesigner14 software tools, the circuit schematic drawing and PCB production were completed. It realizes the function of uploading the video with constant frame rate to the host through wireless transmission, and displaying the video on the host interface in real time. The overall design is characterized by small size, high configuration, light weight, long range, low power consumption, low cost, and has certain engineering value.

1. Introduction

With the development of global information technology, science and technology are changing with each passing day. The new technology forms have brought about changes that can be said to be generational changes in people's daily life [1]. In order to meet some needs of life, researchers have widely applied image acquisition technology and wireless video transmission technology to various fields of life. In the research process of related technologies, mobile phones are used as terminals for video transmission and image acquisition, in order to meet the daily needs of different user groups [2]. In the past data collection and analysis of data transmission experiments, wired transmission has always occupied the mainstream highland due to its advantages of reliability, stability and efficiency, but there are obvious defects in flexibility, disassembly costs, etc. However, with the development and extensive application of Wi Fi technology, the application of WIFI technology makes wireless transmission mode more mobile and scalable than wired transmission mode, It is more convenient to network, saves the trouble of wiring, and becomes more popular [3]. Therefore, electronic equipment and products adapted to Wi Fi technology are gradually necessary for public life.

STM32 series single-chip microcomputer is a series single-chip microcomputer with high cost performance ratio [4]. Its functions are extremely powerful. It is based on the ARM Cortex-M core specially designed for embedded applications that require high performance, low cost and low power consumption. At the same time, it has first-class peripherals: 1 μ S dual 12 bit ADC, 4M bit/s UART, 18M bit/s SPI, etc [5], Use WIFI communication protocol to provide accurate data transmission on

the wireless channel. This enables the user to view clear video images with low delay on the terminal interface.

2. Overall Design Scheme of the System

The hardware part of the remote video communication system designed in this paper includes a power module, a main control module, a communication module, a sensor module and a PTZ steering gear control module. The specific working signal flow diagram is shown in Figure 1. The control module uses STM32 microcontroller; The communication module uses ESP32-CAM development test board to realize wireless communication; The sensor module is mainly a camera module, and CMOS camera OV2640 is selected to collect video images; The executive module is composed of two degrees of freedom actuator pan and tilt, which receives control commands from the host to change the camera angle and realize system movement; This design selects Android terminal as the upper computer to realize graphical operation and display. The software part is mainly developed on the hardware platform. The structure of the STM32 microprocessor uses MFC library functions. This paper can flexibly transplant the driver to the STM32 microprocessor according to the actual needs, so that when the upper computer changes the underlying driver, the interface design of the application layer can enable the application client to work well. In the migration of Wi Fi driver, in order to achieve accurate and fast communication, the concept of WIFI principle and Wi Fi driver standard are analyzed and tested.

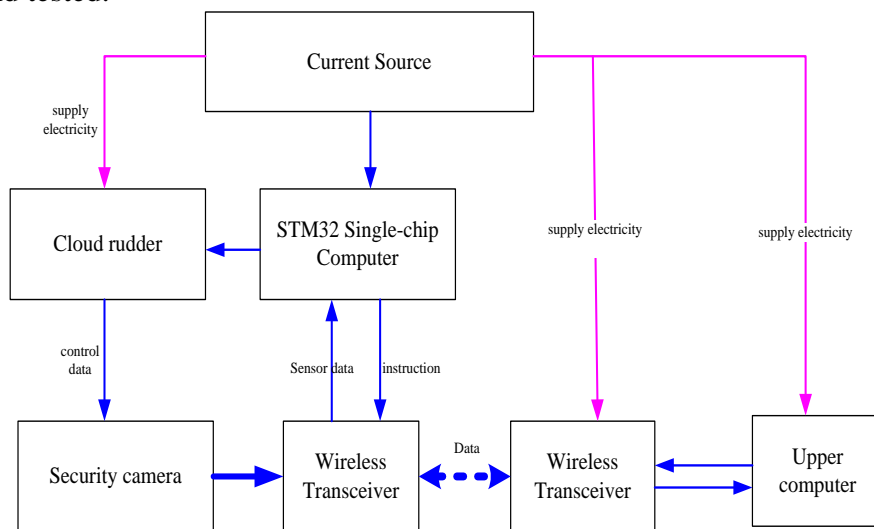

Figure 1: System work flow chart

2.1. Hardware Development Environment

In order to provide a good development environment for the system scheme, a software tool called AltiumDesigner14 is used to draw the circuit schematic diagram and PCB circuit board required by the design. Alti 14 is a good tool for PCB system development. In order to meet the needs of users in various fields, product development tools are integrated to ensure a stable product development environment and performance. At the same time, in order to improve the efficiency of electronic engineers in developing products, this software also covers various tools that engineers need when designing products. Multiple integration libraries are added to the software, which can save the working time of product development and meet the needs of researchers.

2.2. Software Development Environment

In order to ensure the normal development, design and effective use of system equipment, the author uses three programming and development tools, namely KEIL software development platform, Android development tool Android E4A and Visual Studio Code source code editor. Keil development platform is a single-chip software development platform that is often chosen and loved by engineers. Keil software integrates various micro controller environments and has the characteristics of multi-function, easy installation, fast operation and rapid development, which greatly improves the fault diagnosis and design efficiency of electronic engineers. The official version of EasyAndroid is a development programming tool specially designed for Android applications. The latest version of Android E4A has an Android 1.5 software development kit, which can help users easily write Android applications with a basic syntax similar to easy language.

2.3. Selection of Wireless Communication Technology

With the development of science and technology, Bluetooth has become a common way of wireless communication. Today in the 21st century, Bluetooth communication is widely used in various fields. Bluetooth communication is mainly used by users for short distance communication. In mobile devices, users need the technology of high transmission speed and wide transmission distance, but Bluetooth communication cannot meet these two requirements. In 2016, the Bluetooth Technology Alliance proposed Bluetooth 5.0 to improve the speed of low-power devices. However, under low-power conditions, the maximum transmission speed of Bluetooth is only 2Mbps, and the maximum effective transmission distance is 300m. In addition, the feasibility of Bluetooth communication technology is poor, and obstacles also have a greater impact on speed, which greatly reduces the efficiency of information transmission; Exceeding the maximum effective transmission distance of Bluetooth communication will affect or interrupt the transmission of information. ZigBee standard technology based on IEEE802.15.4 is also used, but like Bluetooth communication technology, it has the problems of low transmission speed limit and short transmission distance, which makes it impossible to use in some cases: even at the actual transmission frequency of 2.4GHz, the transmission speed is only 250kbps. The uncertainty of access and transmission mode also causes various problems of information transmission. Mobile technology is the third generation communication technology. Its advantages lie in mobile phone service, navigation service and high data transmission rate. But for engineers, its development and operation costs are high.

The bandwidth of WIFI technology is far higher than Bluetooth, which means that the transmission speed and radio wave transmission are far better than Bluetooth. In addition, Wi Fi technology operates in a higher frequency band to ensure that its terminal data transmission is more stable and reliable than traditional wireless communication technology. The encryption technologies such as WEP and WPA PSK are used to transmit information to the terminal, which ensures the security of information transmission and effectively improves the accuracy, reliability and efficiency of operation. The performance of different radio transmission technologies has defects in many aspects. Traditional and new information transmission technologies have their own advantages and disadvantages, and engineers can choose appropriate information transmission technologies to meet their needs.

3. Design of Main Control Unit and Configuration Circuit of the System

3.1. Main Control Unit and Circuit Selection Design

In order to meet the market demand and the needs of different workplaces, this paper builds the STM32F407 microprocessor system chip on the Cortex-M3 core architecture. Microelectronics (ST)

is a 32-bit microcontroller based on Cortex-M3 core, which belongs to STM32 series microcontroller of ST. This series of chips is prepared by STC based on the principles of low power consumption, low cost and high-speed operation, and also includes a camera interface. The specific configuration diagram of the main control unit is shown in Figure 2.

The maximum main frequency of the selected microprocessor can reach 72MHz. At the same time, the on-chip memory has 1M bytes, the bus matrix in the embedded SRAM includes 128K bytes, and the remaining 64K bytes are in the data bus for CPU performance. According to the characteristics of the above chips, it can be found that the chip can well adapt to the system performance.

In order to improve the computing efficiency of data processing and make complex computing easier to manage, STM32F103 integrates single cycle DSP instructions and a floating point unit (FPU). Dual AHB data bus matrix and multi-channel DMA controller ensure smooth program execution during data transmission. Lingo also simplifies and further speeds up the calculation processing by using separate programs and data operations, greatly reducing the workload of personnel.

The chip has several interfaces, including 1 CAN, 2 I2C, 3 UASRT and a 16 bit timer. Low power consumption, low cost and high chip efficiency greatly improve user acceptance.

During the operation of the system chip, it is necessary to have a stable and suitable voltage environment and meet the requirements of the chip work manual. When designing the system in this paper, it is necessary to add a voltage stabilizing module beside the pin that can perform the voltage stabilizing function, so that the input voltage of the circuit is always 5V.

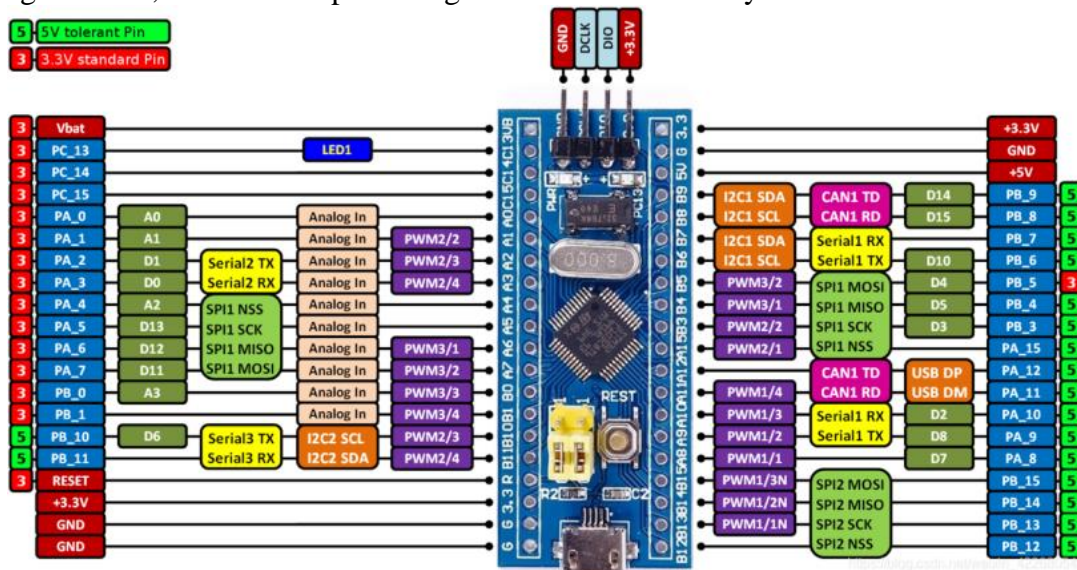

Figure 2: Configuration of main control unit

3.2. Selection and Design of System Sensor Module

The camera module selected in this paper is the CMOS OV2640 camera module of OmniVision Technologies, which is the first fully integrated monolithic 1/4 "2 million pixel CMOS image sensor in the industry, with a pixel size of 2.2um x 2.2um, with 1600 x 1200 pixel image sensor array, so it can support up to 1600 x 1200 resolution, and 1280 resolution x 960 and 640 x 480.[6]

The image sensor supports a series of automatic adjustment functions to adapt the camera to capture video image information under different ambient light conditions, including automatic adjustment of white balance control, exposure function, gain control and other functions, and provides convenient control methods for the camera. In addition to the above color processing, the image

sensor can also improve the video image quality by eliminating interference signals caused by optics and other factors. The built-in 10 bit A/D converter ensures that the output image signal is a digital image signal without A/D conversion. The output image format can be OV2640, which tightly integrates the image sensor and control circuit on a chip, which means that almost all photography functions can be realized on a chip.[7]

3.3. Selection and Design of System Wireless Transmission Module

ESP32 is a WiFi chip launched by Espressif Lexin Information Technology. It has a 40nm process, dual core 32-bit MCU, 2.4GHz dual mode Wi Fi and Bluetooth chips, a main frequency of up to 230MHz, and a computing capacity of up to 600DMIPS.[8]

- Functions such as fine clock adjustment, power saving mode and dynamic voltage regulation.

- Integrated components, such as antenna, RF balancer, power amplifier, low-noise amplifier, filter and power management module, are stable in operation, simple in manufacture, and have a working temperature range of - 40 °C to 125 °C.

- It supports a wide range of communication protocols, including I2C, I2S, SPI, UART and CAN.

- With multiple tuning management modes, the solution can be customized according to different needs.[9]

4. Conclusion

This paper outlines the hardware used in the design of wireless video transmission system, the reasons for choosing this hardware, and the performance comparison between this hardware and other similar components. First of all, the design concept of the subject is a multi-level design concept, which elaborates the detailed analysis of product functional requirements, the method design of the whole system, the method to achieve the specific requirements of the method design and the selection method of the method design; Secondly, STM32F103 hardware circuit is finally selected to solve various problems related to power circuit, including initialization of important modules, such as wireless transmission module WIFI driver and CMOS camera driver. Finally, in order to achieve the goal of real-time image monitoring of Android devices, the development environment of the application layer of Android operating system is based on Windows. The project analyzes wireless transmission and explores its potential market, providing users with solutions for wireless access to images. This design can not only make the image clearer by using CMOS digital image sensor, but also greatly reduce the wiring required for wireless network transmission. In view of the time and other capabilities of this paper, the analysis and design of the system is not deep enough, and there are still many areas that need to be improved, such as market development, optimizing the clarity and smoothness of real-time images, and achieving gain use on different platforms.

References

- [1] Wang Renjie. *Research and Implementation of Wireless Video Transmission Based on WIFI*. Fuyang Normal University, 2021
- [2] Yan Xiaojun. *Research and Design of WIFI Video Transmission Based on STM32*. Central North University, 2016
- [3] Qiu Xulin. *Wifi based wireless video transmission system*. *China New Communications*, 2017,19 (04): 31
- [4] Huang Xiaobin. *A Multifunctional Smart Home Control System Based on STM32 MCU*. Xi'an University of Electronic Science and Technology, 2021
- [5] Zhang Haonan. *Design and Implementation of Wireless Video Transmission Based on STM32F407*. *Electronic Technology and Software Engineering*, 2019 (18): 111-112
- [6] Xiang Wushu, Zhang Jiaqian, Liu Chunlan, Yang Sheng. *Design and Implementation of Smart Home Remote Monitoring System Based on STM32+Wi Fi Technology*. *Industrial Control Computer*, 2018,31 (05): 114-115+118
- [7] Xu Wen, Meng Wen, Zeng Li. *Design of remote monitoring system based on STM32 and WiFi wireless communication*

technology. Automation and Instrumentation, 2016, 31 (11): 35-38

[8] Yang Caisheng, Wu Zhangfei, Wan Guoyi. *Design of image acquisition system based on STM32F407 and OV2640. Automotive Practical Technology, 2018 (13): 142-144*

[9] Wang Jian, Liang Zhentao, Zheng Wenbin, Liu Zhijun. *Design of embedded image acquisition system of STM32 and OV2640. Single chip microcomputer and embedded system application, 2014, 14 (09): 46-48.*