

# *Design and Application of Fuel Supply Device and Fuel Supply Advance Angle Adjustment System*

**Junzhen Gong, Zhenhua Pang, Yuxin Zhang, Sihang Liu, Chunying Zhang**

*Weichai Power Co, Ltd, Weifang, 261061, China*

**Keywords:** Fuel Supply; Diesel Engine; Testing Technology; Fuel Supply Advance Angle; Efficiency

**Abstract:** This paper relates to a fuel supply device and a fuel supply advance angle adjustment system in the field of diesel engine testing technology, the fuel supply device includes: a fuel tank, on which a fuel return interface is formed, a fuel pump, on which a fuel supply interface is formed, and the fuel pump transmits the fuel in the fuel tank to the fuel supply interface; The fuel pump and the fuel supply interface are connected with a throttle valve and a pressure relief valve in turn; The pressure regulating valve is installed on the fuel pump to adjust the fuel supply pressure of the fuel pump. This application enables the operator to complete the fuel supply advance angle adjustment process before the diesel engine is installed on the test bench and connected to the fuel pipeline, greatly improving the test efficiency and production efficiency of the diesel engine.

## **1. Introduction**

The oil supply advance corner is the crankshaft corner of the piston top from the upper stop point when the oil injection pump starts to supply oil to the cylinder. If the oil supply Angle is too small and the oil supply time is delayed, it will cause incomplete combustion, difficult start, insufficient power, and black smoke from the exhaust pipe; If the oil supply Angle is too large, the oil supply time is in advance, there will be start difficulties or reversal, rough explosion, unstable operation, diesel engine power decline, easy to burn cylinder pad, and the cooling water consumption is fast<sup>[1]</sup>.

Current diesel engine oil for early Angle adjustment, need to install the diesel engine on the test stand, attached to test workshop inside the fuel supply system to provide the required fuel, oil for early Angle adjustment, to complete the commissioning operation, increased the test workers labor intensity at the same time, cause the diesel engine test bench time is too long, seriously affect the commissioning efficiency, and then affect the production efficiency of the whole workshop. How to simplify the adjustment operation of oil supply has become an urgent problem to be solved to improve the efficiency of diesel engine test<sup>[2]</sup>.

Therefore, in view of the above deficiencies, this paper designed a fuel supply device and fuel supply early adjustment system, makes the relevant operators can directly after the diesel engine assembly early early adjustment, make the engine installed to the test bench and connect all kinds of process parts of the first time can test operation<sup>[3]</sup>.

## 2. Design of fuel supply device and fuel supply advance angle adjustment system

The fuel supply device includes: the fuel pump has the oil supply interface to the fuel pump; the fuel pump connects the throttle valve and the pressure relief valve; the pressure regulating valve is installed on the fuel pump to adjust the oil supply pressure of the fuel pump<sup>[4-5]</sup>.

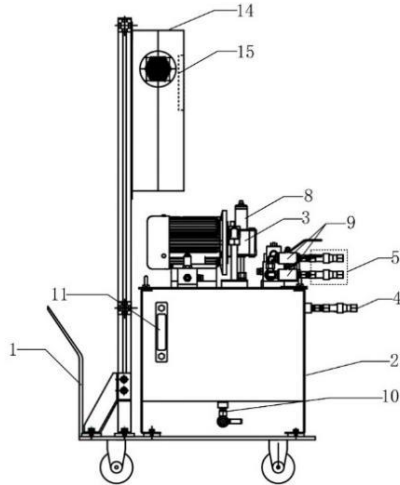

Figure 1: A Schematic diagram of the overall structure of the fuel oil supply unit

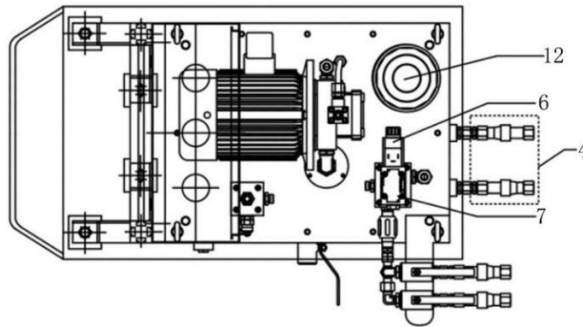

Figure 2: Top view of the fuel supply unit

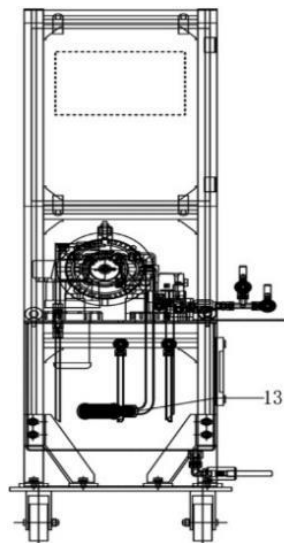

Figure 3: Side view of the fuel supply unit

0-cart, 2-tank, 3-fuel pump, 4-return port, 5-oil supply port, 6-throttle, 7-relief valve, 8-regulator, 9-first ball valve, 10-second ball valve, 11-level gauge, 12-injection port, 13-fuel filter, 14-control box, 15-LCD.

The fuel supply device is used for the fuel supply of the engine, as shown in Fig. 1 and 2 and 3, the fuel supply device includes a cart, a fuel pump mounted on the top of the oil pump; the fuel pump, the fuel pump to the fuel pump, the throttle valve and the relief valve; the fuel pump is equipped with a regulating valve, and the regulating valve is used to adjust the oil supply pressure of the fuel pump.

By using the fuel supply device, the fuel supply device is moved to the target position by a trolley when the diesel engine needs to make fuel supply advance angle adjustment. Then two rubber pipes with pipe joint and hydraulic quick joint are used to connect the fuel supply interface with the fuel inlet of the diesel fuel injection pump and the fuel return interface with the fuel return port of the diesel fuel injection pump respectively. The fuel supply can be realized by setting the fuel supply pressure through the pressure regulating valve and opening the fuel pump. The relevant operators can adjust the fuel supply advance angle directly after the final assembly of the diesel engine is off-line. When the engine is installed on the test bench and connected with various process parts, the test operation can be carried out at the first time. We should give full play to the effective utilization of test bench, improve test efficiency, and then improve the overall production efficiency. In addition, the outlet of the throttle valve is connected to the pressure relief valve. When the oil supply advance Angle is adjusted to meet the requirements, it can immediately discharge the residual pressure of the pipeline and close the fuel pump, so as to reduce the influence of the pipeline residual pressure on the adjustment accuracy of the oil supply advance Angle. Also, meanwhile, compared with the prior art, the device achieves the following technical effects:

1) There is a discharge outlet and ball valve set at the lowest part of the tank, which can easily replace the diesel oil and clean the tank. The fuel tank is equipped with a liquid level gauge, which can observe the fuel liquid level in real time and supplement it in time.

2) The air filter and fuel filter filter the fuel to ensure the cleanliness of the fuel and improve the protection of the diesel engine.

3) Multiple sets of oil supply interface and oil return interface, as well as the addition of ball valve on the oil supply interface, enhance the applicability of different series of diesel engine injection pumps.

### 3. Test validation

#### 3.1 Test and verification



Figure 4: Fuel oil supply unit

Adjust fuel supply device through this design, the pump and interface are standard interface, after production (as shown in figure 4), the test, and the highest process requirements, the test for a large cylinder diameter diesel engine test 10 times, and record data, meet the process requirements of the output power to record 1, do not meet the output power process requirements need to be debugging 0, statistical data in the table below.

Table 1: Test data

number of times	1	2	3	4	5	6	7	8	9	10
Whether the test run output power meets the requirements	1	1	1	1	1	1	1	1	1	1

According to the commissioning results, the compliance rate of adjusting the oil supply lead angle with the device is 100%, and the commissioning time is effectively shortened (as shown in table 1).

At the same time, compared with the existing technology, the design scheme device achieves the following technical effects:

1) There is a discharge outlet and ball valve set at the lowest part of the tank, which can easily replace the diesel oil and clean the tank. The fuel tank is equipped with a liquid level gauge, which can observe the fuel liquid level in real time and supplement it in time.

2) The air filter and fuel filter filter the fuel to ensure the cleanliness of the fuel and improve the protection of the diesel engine.

3) Multiple sets of oil supply interface and oil return interface, as well as the addition of ball valve on the oil supply interface, enhance the applicability of different series of diesel engine injection pumps.

#### 4. Conclusion

This paper designs a fuel supply device and oil supply advance angle adjustment system for the test technology of diesel engine. The principle and instructions of fuel supply device and oil supply lead angle adjustment system are expounded, verified in a series of engine piston test run, confirming that the fuel supply device and oil supply lead angle adjustment system are simple to operate, save manpower, and greatly improve the test efficiency and production efficiency of diesel engine.

#### References

- [1] Zhou Baolong. *Internal-combustion engine science [M]*. Beijing: Machinery Press, 2005.
- [2] Gu Qing. *Oil supply advance angle of measuring device [J]*. *Foreign diesel locomotive*, 1989 (12): 48.
- [3] Hu Bo, Huang Jixuan. *Automatic detection device for diesel engine: CN205936937U [P]*.2017
- [4] Sun Fei. *Design and application of oil angle switching device based on load change of diesel engine [D]*. Hefei University of Technology, 2012
- [5] Xiang Yun. *Advance angle regulating device for diesel engine oil supply [J]*. *Internal combustion engine*, 1987 (03): 16-18 + 20.