

Optimization Design of Suspension and Steering System for FSAE Racing Car

Hongkang Cheng^{a,*}, Bo Wu^b, Daobin He^c

*School of Mechanical & Power Engineering, Harbin University of Science and Technology,
Number 52 Xuefu Drive, Harbin, China*

^achenghongkang2023@163.com, ^b869871621@qq.com, ^c15023427220@163.com

**Corresponding author*

Keywords: FSAE, Racing suspension, Steering system, Optimized design, Finite element analysis

Abstract: The China Formula Student Car Competition has been growing in recent years. In order to improve the steering lightness and body stability of FSAE cars when driving under high-speed and multi-curve conditions. This paper constructs a three-dimensional model of suspension and steering system through CATIA according to the requirements of race rules, applies ADAMS/Car module to simulate the suspension system with two-wheel isotropic excitation, obtains the change curve of suspension performance parameters, and uses ADAMS/Insight module to optimize the unreasonable parameters through the analysis results. Based on the preliminary optimized suspension system, MATLAB is used to optimize the steering trapezoidal mechanism to make the wheel steering on both sides of the race car more closely match the ideal Ackerman geometry relationship. Finally, ANSYS is applied to finite element analysis of the important parts of the suspension and steering system to ensure that their structure and materials can meet the requirements of the whole car design.

1. Introduction

FSAE is a global automotive competition that aims to promote knowledge and skills in automotive engineering and technological innovation, as well as to attract more talented young people to participate in research and development in the automotive and related industries. The competition requires teams to design a small racing car with excellent performance in power, handling and safety within a certain period of time, and to complete the assessment content. The suspension and steering system are two important components of a racing car, whose performance determines the handling stability and smoothness of the car. This paper optimizes the design of the existing suspension and steering system according to the requirements of the competition to improve the smoothness, stability and vibration damping of the racing car when driving under high-speed and curved road conditions.

2. Design of FSAE Racing Suspension System

2.1. FSAE Racing Suspension Design Steps

In this paper, the design steps of the racing suspension are as follows:

- (1) First determine the main parameters of the car, including external dimensions, overall mass and performance;
- (2) Determine the type of suspension, using unequal length double wishbone independent suspension, which has outstanding advantages and is ideal for the selection of FSAE racing cars;
- (3) Determination of front and rear bias frequency of racing car;
- (4) Calculate the stiffness of the suspension;
- (5) Calculate the damping of the suspension;
- (6) Simulation analysis of suspension performance parameters, optimization and improvement of undesirable parameters;
- (7) Perform finite element analysis of important components of the suspension system.

2.2. Determining the Type of FSAE Racing Suspension

Double wishbone independent suspension takes up little space and has no lateral load, which can ensure that the tires can stay close to the ground when the car is turning, improving wheel grip and allowing the driver to turn at a higher speed to improve race performance, so it is suitable for racing cars.

It is known from the competition rules that the high-speed racing car has high requirements for the suspension, but, considering the cost of the suspension and manufacturing assembly and other factors, the advantages and disadvantages of various suspensions are integrated, and the suspension structure of the racing car in this paper is selected as unequal length double cross-arm independent type.

2.3. Selection of Basic Parameters for FSAE Racing

Through the analysis, the selection of the basic parameters of the whole car for FSAE racing is shown in Table 1.

Table 1: FSAE Racing Car Parameters

Name	Parameter
Total weight of racing car (Kg)	300
Quality distribution (%)	Pre 45% Post 55%
Wheelbase (mm)	1580
Tire free radius (mm)	227.5
Height of center of mass (mm)	300
Mass on the spring (Kg)	225

2.4. Bias Frequency of FSAE Racing Suspension

The bias frequency is the inherent frequency of the suspension and spring loaded masses that make up the vibration system. It has a significant impact on the comfort of the ride and the stability of the handling of the car. The bias frequency is calculated by combining the above racing parameters as follows:

$$f = \frac{1}{2\pi} \sqrt{\frac{K}{m}} \quad (1)$$

In the above equation: K - total racing stiffness (N/cm); m - quality of the load (kg).

The choices of bias frequency require various considerations: (1) Generally high in the front and low in the rear in terms of the handling stability of the car; (2) Considering the smoothness of the racing car, usually low in the front and high in the rear; (3) Need to consider the adverse effects of resonance on racing cars^[1].

Due to the different types of racing cars, the polarization frequencies of the cars are chosen differently. Unreasonable bias frequency can lead to failures such as runout and heavy steering. If high smoothness is required, the bias frequency will be smaller and vice versa. In order to avoid resonance, the selection of front and rear bias frequencies cannot be the same. Referring to the racing car designs of strong teams at home and abroad and previous design experiences, and considering all factors, the front and rear suspension offset frequencies of this paper were finally determined to be initially set as follows: $f_F = 3.0Hz$ and $f_R = 2.8Hz$.

2.5. Calculating the Suspension Stiffness of FSAE Racing Car

Determine the suspension stiffness of the car based on the previously determined bias frequency and overall car parameters.

(1) Calculation of total stiffness K

Reasonable FSAE racing stiffness ensures that the body has the ability to resist deformation when subjected to external forces of impact. The total stiffness K is calculated as follows:

$$K = 4\pi^2 f^2 m/2 \quad (2)$$

Where: f is the suspension bias frequency; m is the quality of the load.

(2) Calculation of suspension stiffness

Among the suspension design parameters, suspension stiffness is a measure of the suspension's ability to resist deformation. Since the suspension stiffness and tire stiffness conform to a spring series relationship, the formula for calculating the series connection between the two and the total racing stiffness is as follows:

$$\frac{1}{K} = \frac{1}{K_s} + \frac{1}{K_w} \quad (3)$$

Further derivation yields:

$$K_s = \frac{K_w \cdot K}{K_w - K} \quad (4)$$

In the above equation: K_s is the suspension stiffness; K_w is the tire stiffness.

2.6. Calculating the Damping of Suspension Dampers

Shock absorber damping is calculated as follows:

$$\zeta = 4\pi \cdot m_c \cdot f \cdot \varphi \quad (5)$$

where: φ is the relative damping coefficient; m_c is the mass on the spring; and f is the bias

frequency.

In general, the damping coefficient of the suspension shock absorber should be chosen to be larger in the tensile stroke, and the opposite in the compression stroke. Considering the importance of smoothness to racing cars, therefore, by studying the damping coefficients of racing cars in previous races, the relative damping coefficients of suspension dampers selected for FSAE racing cars in this paper are: 0.5 for tensile stroke and 0.4 for compressive stroke.

3. FSAE Front Suspension Kinematic Simulation Optimization for Racing Cars

3.1. Front Suspension Modeling

FSAE racing cars require the suspension to be able to effectively cushion the impact force transmitted to the wheels or body by the road in high-speed, multi-curve driving conditions. The criteria for judging the excellence of the suspension system is the variation of its kinematic parameters within a specified range during the up and down reciprocal jumping stroke of the wheels, in which the front suspension kinematic characteristics are closely related to the racing performance. In order to simulate and analyze its kinematic characteristics, this paper establishes the front suspension simulation model through ADAMS/Car module of ADAMS software, as shown in Figure 1.

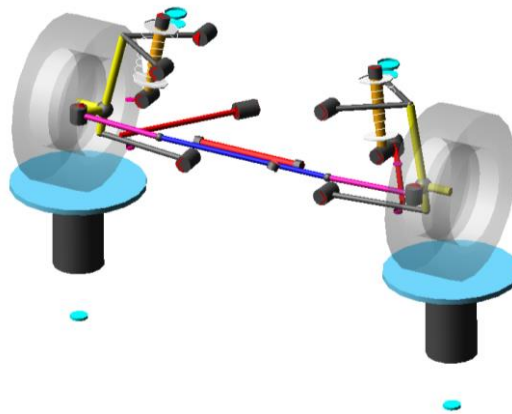

Figure 1: Racing Car Front Suspension Simulation Model

3.2. Front Suspension System Simulation Analysis

In the course of the race, due to the unevenness of the road or the driver's acceleration, braking, turning and other operations will cause the wheels to jump back and forth in the vertical direction. Therefore, under the condition that both wheels jump up and down at the same time, we simulate and analyze the change law of the wheel positioning parameters of the suspension, and use it as a basis to analyze and optimize the suspension motion characteristics. In this paper, the simulation of two-wheel isotropic excitation is carried out by ADAMS/Car, and the upper and lower wheel runout travel is set to 30mm, and the following suspension performance parameter variation curves are obtained.

- **Toe angle of front wheel**

Toe angle of front wheel controls the steering performance of the vehicle and maintains proper wheel alignment to ensure proper contact between the wheels and the axle. In addition, the lateral roll of the wheels can be controlled, thus effectively reducing wheel slip. When the wheels jump up and down, the change of toe angle will lead to deterioration of vehicle handling performance and also cause vehicle vibration, the simulation curve of which is shown in Figure 2.

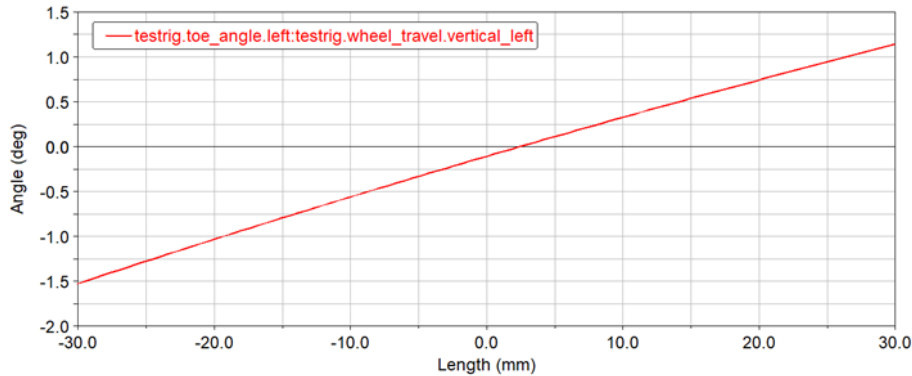

Figure 2: Toe Angle Simulation Curve

As in the image above, Toe angle is -0.125° in static equilibrium, which meets the basic requirements. Toe angle changes in the positive direction with a change of almost 1.25° during the 30 mm upward wheel jump and in the negative direction with a change of 1.38° during the -30 mm downward wheel jump. However, the total variation of the toe angle is 2.63° during the whole two-wheel isotropic excitation simulation, excessive range of variation. For racing cars driving at high speed on multi-curves, this seriously affects their handling stability and needs to be optimized.

● **Front wheel camber**

Reasonable front wheel camber allows the vehicle to maintain optimal handling direction during driving so that the vehicle can more easily resist lateral forces and improve lateral stability. When the car is driving in the corner, in order to increase the lateral force provided by the wheels and enhance the grip of the tires, the camber angle should be set to a negative value, while maintaining its tendency to change positively when the wheels jump down and negatively when they jump up. The camber simulation curve is shown in Figure 3.

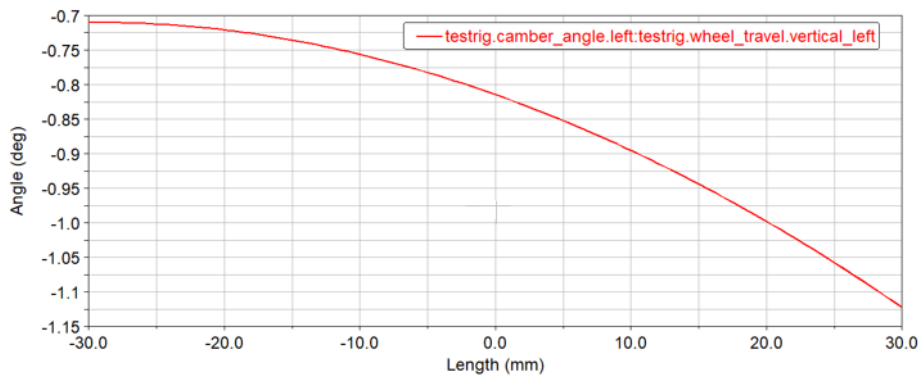

Figure 3: Front Wheel Camber Simulation Curve

From the above figure, it can be seen that the camber angle variation is only 0.4° throughout the wheel runout travel, which is a small variation and meets the design requirements and does not need to be optimized.

● **Caster angle**

The caster angle plays a role in stabilizing the vehicle in a straight line and can effectively stifle the steering oscillation and make the steering force moderate. During the race, the steering torque of the FSAE car increases as the caster angle increases, resulting in heavy steering, and decreases as the caster angle decreases, causing the car to be unable to drive in a straight and stable line. Therefore, a reasonable caster angle ensures that the car steers lightly while maintaining its stability. The simulation results are shown in Figure 4. When the tire is stationary, the caster angle is 4.9° , which is

within a reasonable range, but the amount of angle change is too large during the up-and-down jumping stroke of the wheel, which needs to be optimized.

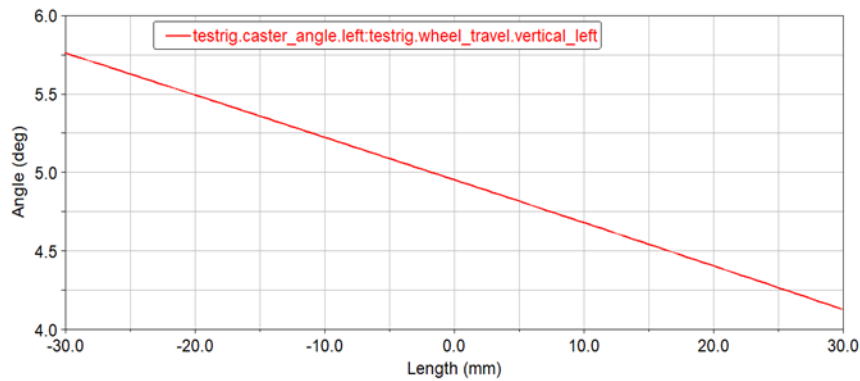

Figure 4: Caster Angle Simulation Curve

● Kingpin inclination angle

The kingpin inclination angle helps the wheels on both sides of the front suspension to return to the front automatically, and also reduces the offset distance of the main pin from the wheel center in the transverse plane, thus reducing the return torque and making it easier for the driver to control the steering wheel^[2]. The simulation results are shown in Figure 5.

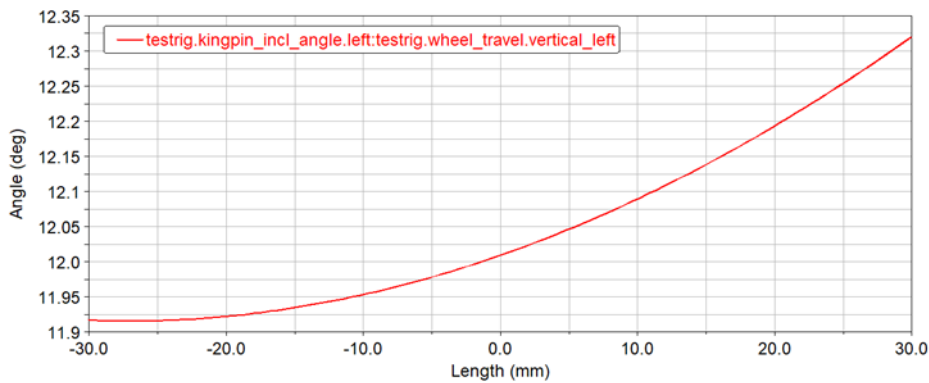

Figure 5: Kingpin Inclination Angle Simulation Curve

As can be seen from Figure 5, the variation of the kingpin inclination angle ranges from 11.925° to 12.325° throughout the simulation of the two-wheel isotropic excitation. Excessive kingpin inclination angle will cause sliding between the tire and the ground, increasing the degree of tire wear, and generally requires that the value of the kingpin inclination angle is increasing during the wheel hopping stroke. During the whole simulation, the kingpin inclination angle changes within 0.4° , which meets the design requirements and is more desirable.

3.3. Front Suspension System Optimization

From the simulation results of the above front suspension positioning parameters, it can be seen that the toe angle and the caster angle change too much in the wheel hopping stroke, therefore, the above two wheel positioning parameters are selected as the optimization target. Among the hard point coordinates of the suspension structure, several coordinate points with the greatest influence on the optimization target are selected as design variables, mainly the Y and Z coordinates of the four articulation points of the upper cross-arm, lower cross-arm and frame, a total of eight variables. The optimization analysis was performed by ADAMS/Insight module in ADAMS, and the analysis results

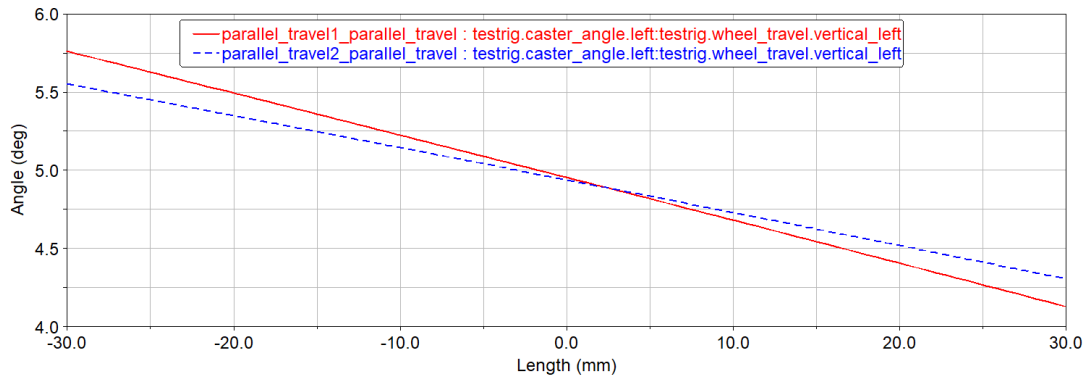

Figure 9: Simulation Curve Before and After Caster Angle Optimization

From the above figure, it can be seen that the toe angle and caster angle changes are reduced, which improves the driving stability of the car and achieves the purpose of optimizing the front suspension performance parameters.

4. Design of FSAE Racing Steering System

4.1. FSAE Racing Steering System Design Steps

The design steps of the racing car steering system in this paper is as follows:

- (1) Design the steering wheel of the car according to the general arrangement requirements;
- (2) Design the basic parameters of the steering system;
- (3) Further optimization of the steering trapezoidal mechanism based on the optimization of the suspension system;
- (4) Perform finite element analysis of important components of the steering system.

4.2. Design of Steering Wheel

The steering wheel is the most important component that comes into direct contact with the racer. The maximum one-sided turning angle of the steering wheel is usually within 150° , so the racer can hold the same part of the steering wheel all the way through the race. We used this to design a racer's tight grip. According to the requirements of the race, the steering wheel should not be too big, however, considering that there is no steering assistance device, the size of the steering wheel is as big as possible. Combining all factors, this paper determines the diameter of the steering wheel as: $R_w = 255mm$. At the same time, in order to better meet the ergonomics, the steering wheel should be positioned as far up as possible to provide more space for the legs. The angular arrangement of the steering wheel is determined by the actual operation of the racer, and its specific structure is shown in the figure 10.

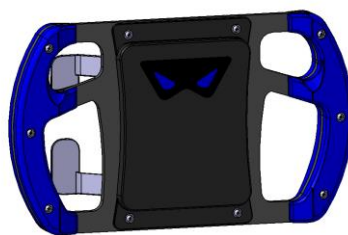

Figure 10: Design of Steering Wheel

4.3. Determine the Basic Parameters of the Steering System

4.3.1. Steering System Angle Ratio

The angular ratio of the steering system affects the force ratio, which can coordinate lightness and sensitivity. Depending on the nature of the race, more steering agility is sought on the track, so the maximum steering wheel angle is usually no more than 150°. Take the maximum steering wheel angle is 140°, then the steering system angle transmission ratio is:

$$i_w = \frac{\Delta\varphi_{w\max}}{\frac{\Delta_{i\max} + \Delta_{o\max}}{2}} \quad (6)$$

Where: $\Delta_{w\max}$ is the maximum angle of the steering wheel; $\Delta_{i\max}$ and $\Delta_{o\max}$ are the maximum angle of the inner and outer wheels respectively.

4.3.2. Steering System Force Transmission Ratio

The steering system force transmission ratio can be calculated by the following equation:

$$i_T = \frac{T_w}{T_h} \quad (7)$$

Where: T_w is the torque overcome by the steering knuckle during steering travel; T_h is the torque applied by the racer on the steering wheel.

The steering system force transmission ratio can be further expressed as follows:

$$i_T = i_w \cdot \eta_{SG} \cdot \eta_{SL} \quad (8)$$

Where: η_{SG} is the efficiency of the steering gear, usually 90% for rack and pinion steering; η_{SL} is the efficiency of the steering transmission mechanism, usually taken as 85% to calculate.

4.3.3. Maximum Steering Angle of Front Wheels

According to the relevant requirements of the race, the minimum turning radius of the track is 9m, and referring to the design requirements of the track in previous years, this paper finally determines the minimal turning radius of a car is $R_{\min} = 4m$.

Using the minimal turning radius, the maximal turning angle of the outer wheel is obtained according to the following equation:

$$\theta_{o\max} = \arcsin \frac{L}{R_{\min} - c} \quad (9)$$

4.4. Design of Steering Gear

4.4.1. Determine the Type of Steering Gear

Rack and pinion steering gears are mostly used in FSAE racing due to their small size, light weight, simple structure and high transmission efficiency. In addition, the rack and pinion has a high reverse efficiency and relatively low road backlash, providing better road feedback.

For these reasons, the rack and pinion steering was finally adopted as the steering gear for our racing car steering system in this paper.

4.4.2. Calculated Load of Steering System

Usually, the moment is the largest when the car is steering in place. Therefore, the steering moment of the car is taken as the calculated load of the steering system, and the formula is shown as follows :

$$M_R = \frac{f}{3} \sqrt{\frac{G_1^3}{p}} \quad (10)$$

Where: f is the coefficient of sliding friction between the tire and the road, taken as 0.8; G_1 is the vertical load of the wheel; p is the tire pressure.

4.4.3. Calculation of the Hand Force Acting on the Steering Wheel

Using M_R , the type of steering gear and the structure of the steering guide rod system, the hand force acting on the steering wheel can be obtained F_h :

$$F_h = \frac{2l_1 M_R}{l_2 D_{SW} i_w \eta_{SG}} \quad (11)$$

Where: D_{SW} is the diameter of the steering wheel; i_w is the steering system angle ratio; η_{SG} is the rack and pinion steering efficiency.

5. FSAE Racing Car Steering Trapezoidal Mechanism Optimization Design

5.1. Ideal Ackerman Geometry of Steering System

FSAE race cars need to have the ability to corner quickly with less tire wear, which requires the vehicle's inner and outer wheel angles to conform to the ideal Ackerman geometry, improve steering stability, and reduce tire deflection wear. That is, when the vehicle is steered, the inner and outer wheels do pure rolling around the same instantaneous center^[3], see Figure 11. The mathematical expression for the ideal Ackerman geometric relation is:

$$\frac{K}{L} = \cot \theta_o - \cot \theta_i \quad (12)$$

Where, K is the distance between the extension of the center of the main pin of the inner and outer wheels and the intersection of the horizontal plane; L is the wheelbase; θ_o is the outer wheel turning angle; θ_i is the inner wheel turning angle.

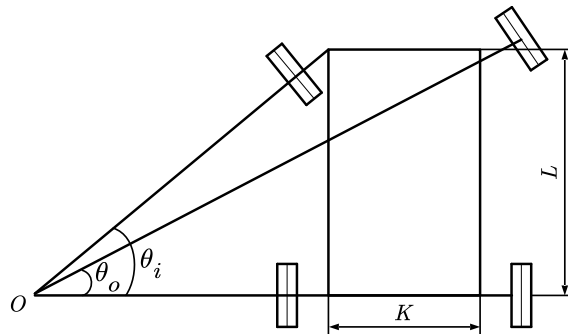

Figure 11: Ideal Ackerman Geometric Relations

5.2. Mathematical Model of Steering Trapezoidal Mechanism

According to the requirements of the competition, the suspension structure adopts double cross-arm independent type, so the steering ladder mechanism is chosen with its corresponding disconnected type, as shown in Figure 12.

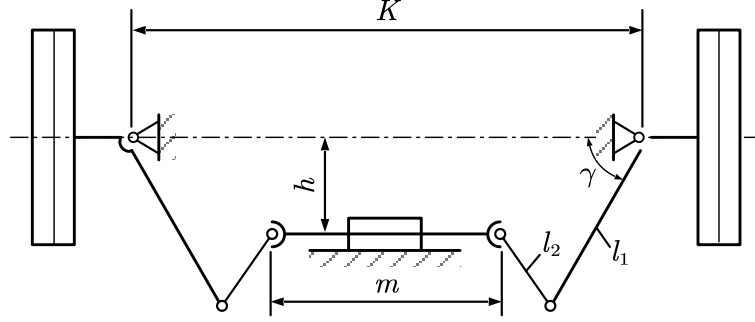

Figure 12: Sketch of Disconnected Steering Ladder Structure

When racing through a corner, a reasonable steering trapezoidal mechanism can make the inner and outer wheel angles meet the requirements of doing pure rolling, and ensure that the front and rear wheels move around the same steering transient center. Based on the geometric relationship in the above figure, the following expressions for the steering trapezoid parameters are obtained.

- Length of steering cross-tie bar l_2 :

$$l_2 = \sqrt{\left(\frac{k-m}{2} - l_1 \cos \gamma\right)^2 + (l_1 \sin \gamma - h)^2} \quad (13)$$

- Inside wheel turning angle θ_i :

$$\theta_i = \cos^{-1} \left[\frac{l_1^2 + h^2 + \left(\frac{k-m}{2} + s\right) - l_2^2}{2l_1^2 \sqrt{h^2 + \left(\frac{k-m}{2} + s\right)^2}} \right] + \tan^{-1} \left(\frac{2h}{k-m-2s} \right) - \gamma \quad (14)$$

- Outside wheel turning angle θ_o :

$$\theta_o = \gamma - \tan^{-1} \left(\frac{2h}{k-m+s} \right) - \cos^{-1} \left[\frac{l_1^2 + h^2 + \left(\frac{k-m}{2} + s\right)^2 - l_2^2}{2l_1 \sqrt{h^2 + \left(\frac{k-m}{2} + s\right)^2}} \right] \quad (15)$$

In the above equations, l_1 is the trapezoidal arm length, γ is the steering trapezoidal base angle, m is the rack length, s is the rack travel, k is the wheelbase, and h is the distance from the gear to the front axle.

5.3. Optimization of Steering Trapezoidal Mechanism Using MATLAB

According to the mathematical model of the steering trapezoidal mechanism established in section 5.2, the base optimization variables are determined as the steering trapezoidal base angle, the trapezoidal arm length, and the distance from the gear to the front axle. Considering the interference problem of suspension and steering system guide bar system comprehensively, the values of

optimization variables are constrained and the range is shown in Table 3.

Table 3: Optimization of the Range of Values of Variables

Optimization variables	Initial value	Range of values
Steering trapezoid base angle γ (°)	67	60-70
Trapezoidal arm length l_1 (mm)	129	125-135
Distance from gear to front shaft h (mm)	55	50-60

The optimization objective of the steering trapezoidal mechanism is to make the actual inner and outer wheel turning angles closer to the ideal Ackerman geometric relationship within the specified steering angle range, using a discrete-type approach, and determining the optimization objective function as follows:

$$f(x) = \sum_{\theta_o}^{\theta_{o\max}} \omega(\theta_{o2} - \theta_{o1}) \quad (16)$$

In the above equation, θ_{o1} is the outside wheel turning angle satisfying the ideal Ackerman geometry relationship; θ_{o2} is the actual outside wheel turning angle; ω is the weight coefficient, considering the tire wear, and 0.5 is taken in this paper.

The nonlinear constraints were established by MATLAB software for optimization, and the optimal solutions of the steering trapezoidal parameters were obtained, as well as the comparison curves of the wheel turning angles on both sides of the car with the ideal Ackerman turning angles before and after optimization. As shown in Table 4 and Figure 13, respectively.

Table 4: Optimal Solution for Steering Trapezoid Parameters

Optimization variables	Optimum value
Steering trapezoid base angle γ (°)	64
Trapezoidal arm length l_1 (mm)	130
Distance from gear to front shaft h (mm)	44

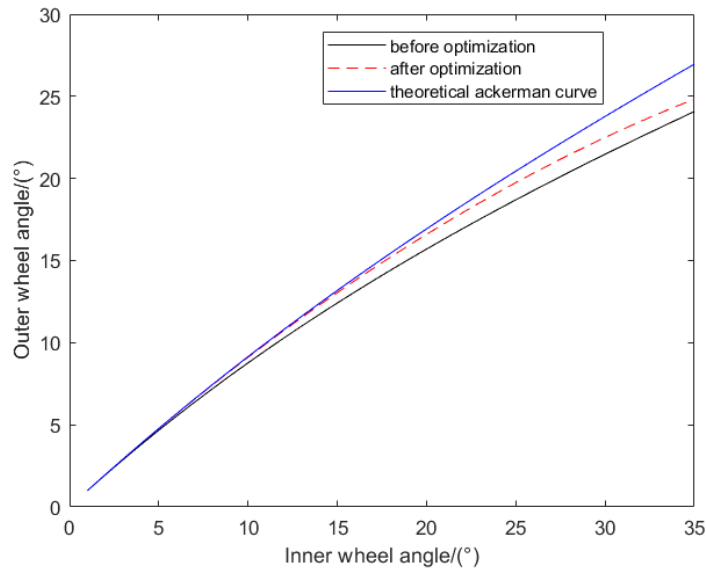

Figure 13: Inner and Outer Wheel Angle Optimization Before and After Comparison

As can be seen from the above figure, the optimized steering inner and outer wheel curves basically match the ideal curve, which indicates that the steering trapezoid mechanism optimization effect is remarkable, which can make the car have better handling performance, and the body has a smoother and more stable cornering attitude.

6. Finite Element Analysis of Important Parts of Suspension and Steering System

The purpose of using ANSYS software to analyze the important components of FSAE racing suspension and steering system is to understand the force situation of the components under different working conditions to ensure whether their strength meets the design requirements and to improve the structural design of the components so as to protect the life safety of the drivers^[4].

6.1. Finite Element Analysis of the Front Column of the Suspension System

First, the 3D model of the front column created in CATIA software was imported into ANSYS static structural analysis module, and the repetitive point, line and surface features in the model were solved through pre-processing to simplify the model structure. Before conducting meshing, material properties need to be set. The material of the column before racing in this paper is 7075 aluminum, which has the advantages of high strength, good thermal conductivity, corrosion resistance and impact resistance, etc. It is suitable for the column structure which is subjected to various loads, and its material property parameters are shown in Table 5.

Table 5: 7075 Aluminum Material Properties

Material name	Densities	Modulus of elasticity	Poisson ratio	Yield strength limit
7075 Al	$2.81 \times 10^3 \text{ kg/m}^3$	71Gpa	0.33	455Mpa

As the front column of the suspension is an irregular three-dimensional entity, so the grid division cell is preferred to tetrahedral free division, the analysis accuracy is higher, set the cell side length to 4mm, the grid distribution is more uniform.

Under racing braking conditions, the front column is subjected to the greatest load, and the fixed restraint is applied to the inner bore of the front column. The total deformation and stress diagrams are shown in Figure 14 and Figure 15 by solving for a force of 1600N on the suspension lugs, a bearing force of 3000N on the bearing end face, and a torque of 8600N · mm on the brake caliper.

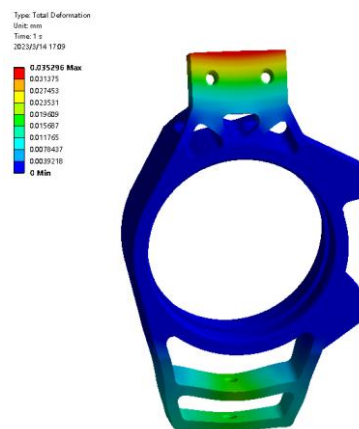

Figure 14: Front Column Total Deformation Diagram.

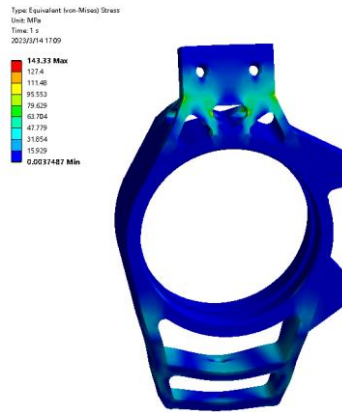

Figure 15: Front Column Stress diagram.

From the above figure, it can be seen that the maximum deformation of the front column occurs at the upper end of the lugs, which is only 0.035 mm , meeting the design requirements of the front column stiffness. The maximum equivalent stress is 143.33 Mpa , which is much smaller than the yield strength of 7075 aluminum, indicating that the structure and material of the front column of the designed suspension system can meet the requirements of the racing car under braking conditions.

6.2. Finite Element Analysis of Steering System Gear Shaft

The gear shaft is connected to the universal joint and is responsible for receiving the force and torque transmitted to the steering wheel by the universal drive. Finite element analysis of the CATIA designed gear shaft model was performed by ANSYS. First, the material property of the gear shaft is set to 40Cr, and the material property are shown in Table 6. The advantages of using 40 Cr as the material of gear shaft are good mechanical properties after tempering, good low temperature impact toughness and easy cutting. Then the tetrahedral cell type is used to freely divide the mesh. Fixed constraints are applied to both end faces of the gear shaft model. After applying a torque of $60\text{ N} \cdot \text{mm}$, the solution is processed. The total deformation diagram and stress diagram are shown in Figure 16 and Figure 17.

Table 6: 40Cr Material Properties

Material name	Densities	Modulus of elasticity	Poisson ratio	Yield strength limit
40Cr	$7.82 \times 10^3\text{ kg/m}^3$	206 Gpa	0.3	785 Mpa

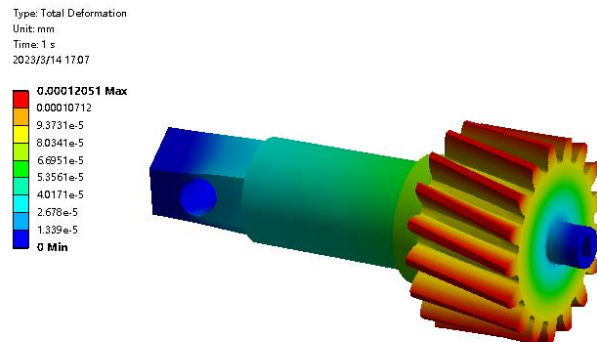

Figure 16: Total Gear Shaft Deformation Diagram

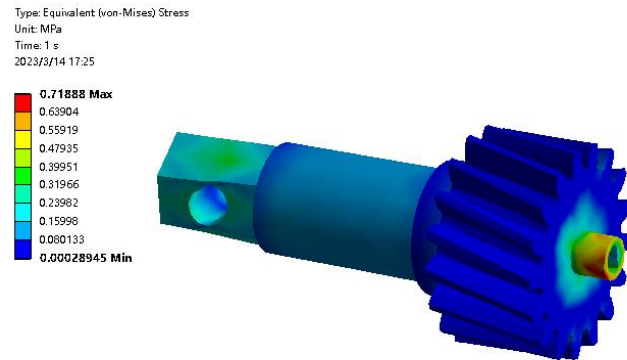

Figure 17: Gear Shaft Stress Diagram

From the above figure, it can be seen that the maximum deformation and the maximum stress value of the gear shaft designed in this paper are less than the limit value of the material properties and meet the design requirements of the FSAE competition.

7. Conclusion

This paper optimizes the design of suspension and steering system of FSAE racing car. Firstly, the 3D model of the suspension and steering system of FSAE racing car was established by CATIA. Secondly, the ADAMS/Car module is applied to simulate the two-wheel isotropic excitation of the suspension system to obtain the simulation curves of the suspension performance parameters with wheel travel, and the unreasonable performance parameters are optimized by the ADAMS/Insight module. Based on the optimization of the suspension system, this paper uses MATLAB to optimize the steering trapezoidal mechanism so that the racing car has better handling performance. Finally, ANSYS was applied to finite element analysis of the important components of the suspension and steering system to ensure that their structure and materials could meet the requirements of the whole vehicle design.

References

- [1] Jianyu Wu. (2011). *Research on the design and optimization of the suspension of Formula Student Racing Car* (Master's thesis, South China University of Technology).
- [2] Hang Wang, Lin Yang, Renjie Peng & Yong Feng. (2013). *ADAMS-based Front Suspension Optimization Design for FSAE Racing Cars*. *Journal of Guangdong University of Technology* (03), 105-108.
- [3] Sizhong Chen, Jun Ni & Zhicheng Wu. (2012). *Track-specific steering trapezoid optimization and virtual testing for formula cars*. *Mechanical Drives* (09), 67-70.
- [4] Guofei Yu, Hongwu Huang & Junhui Wu. (2009). *Strength and stiffness calculation and analysis of FSAE racing car frame based on finite element*. *Journal of Xiamen Institute of Technology* (04), 29-32. doi:10.19697/j.cnki.1673-4432.2009.04.006.