

# *Research on the Application of LSTM Neural Network Model in Text Sentiment Analysis and Sentiment Word Extraction*

**Junpeng Hu, Yegang Li\***

*School of Computer Science and Technology, Shandong University of Technology, Zibo, 255049  
Shandong, China*

*\*Corresponding Author*

**Keywords:** LSTM, GCN, Emotional analysis, Fine-grained emotion

**Abstract:** With the continuous development of neural network, many scholars who study natural language innovatively introduce neural network to improve the existing language model. This paper focuses on the application of LSTM (Long Short Term Memory) neural network model in text emotion analysis and emotion word extraction. A text emotion analysis model based on LSTM neural network model is proposed, which consists of two parts: LSTM and GCN (Graph convolution network). The LSTM model is used to effectively identify the fine-grained emotions in comments, and then the improved GCN is used to capture the structural information on the dependency graph, so as to realize the enhanced feature extraction of GCN emotional words, and finally realize the extraction of emotional words. The research results show that the accuracy of the improved algorithm proposed in this paper reaches 90% in the recognition of four emotional tendency categories, which proves the feasibility of the improved algorithm.

## **1. Introduction**

Text sentiment analysis and sentiment word extraction is a task in NLP(natural language processing), which has a large number of applications, such as information storage and recovery technology, web classification and so on [1-2]. The corresponding text emotional analysis and emotional word extraction of commodity reviews can not only know whether the public likes or dislikes commodities, but also help merchants to put forward corresponding purchase suggestions to customers and improve their commodities and services, thus improving the commercial value of commodities. Aspect-level sentiment analysis belongs to fine-grained sentiment analysis, which aims to predict the emotional polarity of a specific entity or aspect in a text, and its key lies in extracting text representation [3]. Literature [4] uses LSTM (Long Short Term Memory) for sentiment analysis, and the experimental results show that LSTM can model context representation more effectively. Although the above methods have achieved good results in text representation, they still ignore syntactic structure information such as dependency tree. Literature [5] uses LDA(Latent Dirichlet Allocation) topic model to extract product attribute features, and classifies the extracted attribute words into LDA topics. However, LDA topic model tends to extract topic

words with high frequency and global nature, and the recall rate of attribute words with low frequency is not high, and the topic allocation of fine-grained words is not easy to control. Literature [6] added prior knowledge to the model to guide feature extraction, and proposed AKL(automated knowledge LDA) model. The prior knowledge was obtained automatically from the big data of product reviews without manual input, and it came from different product fields.

With the continuous development of neural network, many scholars who study natural language innovatively introduce neural network to improve the existing language model [7-8]. This paper focuses on the application of LSTM neural network model in text emotion analysis and emotion word extraction. A text emotion analysis model based on LSTM neural network model is proposed, which consists of two parts: LSTM and GCN (Graph convolution network).

## 2. Research Method

### 2.1 Fine-Grained Sentiment Analysis Based on LSTM

Emotion is “people's attitude experience about whether objective things meet their own needs”. People's emotions, attitudes, opinions or evaluations about certain things are regarded as the expression of emotions [9]. The analysis of online comments based on sentence level and text level is the main task of traditional sentiment analysis, that is, coarse-grained sentiment analysis. Traditional sentiment analysis mainly adopts the following two methods: the method based on sentiment dictionary and the method based on machine learning.

In general, fine-grained sentiment analysis can be divided into the following steps: first, extract opinion sentences; Then emotional words and attribute words are extracted and matched; Finally, the degree of emotional tendency of emotional words is calculated. In the research of fine-grained sentiment analysis, product attributes are divided into explicit attributes and implicit attributes. There are more researches on the extraction of explicit attributes and less on the extraction of implicit attributes. The research on emotional polarity mainly focuses on English comments, but there is no systematic solution to Chinese comments.

The LSTM neural network replaces the modules in the RNN( Recurrent Neural Network) hidden layer with memory cells, and it uses the structure of “gate” to let information pass selectively. LSTM has three gates: forgetting gate, input gate and output gate. The structure of LSTM can be shown in Figure 1:

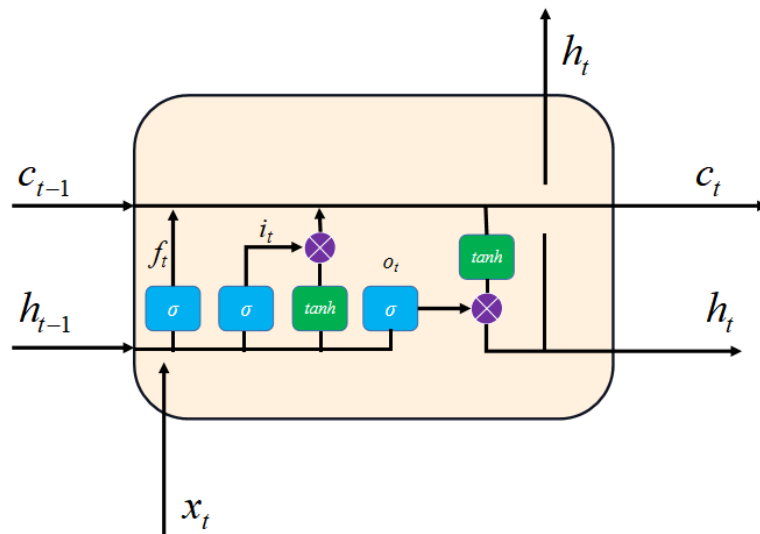

Fig.1 Structure of LSTM

From the perspective of language model, LSTM can be regarded as an improvement of RNN. They all take text sentences as input sequences and calculate their confusions under different models. Comparing the confusions, it shows that the emotions of the text sentences are more likely to be biased towards those of models with less confusions.

In the task of text emotion analysis and emotion word extraction, fine-grained emotion analysis can reveal users' feelings about products from multiple dimensions, which can not only provide decision support for consumers when shopping, but also provide improvement direction for merchants when optimizing products. The fine-grained text sentiment analysis model proposed in this paper can be roughly divided into three stages (Figure 2):

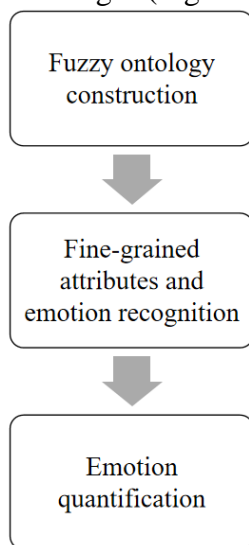

Fig.2 Fine-Grained Sentiment Analysis Process

Construction stage of fuzzy ontology. The fuzzy binary inclusion relationship between attributes is obtained by using the concept hierarchy learning algorithm, and the fuzzy ontology that unifies the concept of attributes and reveals the subordinate relationship between attributes is obtained. Fine-grained emotion recognition stage. Multi-layer attribute labeling is carried out on the comment data; Then, a multi-layer attribute recognition model and an emotion recognition model are constructed based on LSTM. Finally, these two models are used to effectively identify fine-grained emotions in comment information. Emotional quantification stage. The emotion measurement model of single attribute, attribute class and product as a whole is constructed, and the user's emotion to the product is quantitatively analyzed from multiple dimensions.

## 2.2 Feature Extraction of GCN Emotional Words Enhancement

It is more and more difficult for GCN to get useful information from massive unstructured online comment text data, and it is hoped that these comment documents can be automatically processed and analyzed by corresponding technologies to extract useful knowledge. Commodity reviews are unstructured text data expressed in natural language, and the amount of data is huge. It is necessary to comprehensively use natural language understanding and data mining technology, and effectively reduce the data representation dimension of the text, so as to realize fine-grained feature and emotional word mining.

Deep learning technology adopts multi-layer neural network structure to automatically learn feature representation, which has been successfully applied in image, voice, NLP and other fields. The traditional machine learning method needs to build feature sets manually, and the features built in this way depend on the experience of feature engineers, which is time-consuming and cannot

guarantee the comprehensiveness of features. GCN can be divided into spectrum-based GCN and space-based GCN. Spatial GCN is a messaging mode that can operate on any graph on a local graph [10], so it is more popular than spectrum-based GCN, especially in NLP, social networks and other fields.

In this paper, the text vector and the adjacency matrix of syntactic dependency tree are used as the input of GCN. In the dependency tree, the vector representation of words is used as nodes and the association between words is used as edges. In this way, through GCN, the features of nodes can be updated according to their own word vector features and their association with other words.

Assuming that an  $L$ -level GCN works on a dependency graph  $g = (v, \varepsilon)$ , where  $v, \varepsilon$  is a node set and an edge set respectively, then the calculation of the output representation  $h_i^{(k)}$  of node  $i$  at the  $k$ -th level is shown in Formula (1):

$$h_i^{(k)} = \rho \left( \sum_{j=1}^q A_{ij} W^{(k)} h_j^{(k-1)} + b^{(k)} \right) \quad (1)$$

Where,  $h_j^{(k-1)}$  represents the output representation of node  $j$  at the  $k-1$  layer GCN,  $W^{(k)}$  represents the weight matrix,  $b^{(k)}$  represents the partial differential vector,  $\rho(\cdot)$  represents the activation function RELU, and  $A$  represents the adjacency matrix of the dependency in the dependency tree.

The relationship between feature mapping and classification is coordinated by replacing the traditional maximum pooling layer. On the one hand, a problem in the full connection layer hinders the speculative ability of the whole network; On the other hand, when the regularizer performs training, it largely prevents over-fitting. Then the subsequent vectors are directly input into the softmax function to get the likelihood distribution. Equation (2) describes the probability occupation of emotion analysis.

$$P(i_j | k, \theta) = \frac{\exp(x_j(k, \theta))}{\sum_{1 \leq i \leq |X|} \exp(x_j(k, \theta))} \quad (2)$$

Where  $x_j(k, \theta)$  is the average pool result; Parameter set  $\theta$  corresponds to class  $j$ ; The class space is represented as  $X$ . In order to minimize the negative logarithmic probability, the random gradient descent method is used.

The end-to-end back propagation algorithm is used to train the model, and the loss function uses the cross entropy function, as shown in Formula (3). L2 regularization is added to avoid over-fitting. The model is optimized by minimizing the loss function, and AdaGrad is used as the optimization method.

$$loss = - \sum_i \sum_j y_i^j \log \hat{y}_i^j + \lambda \|\theta\|^2 \quad (3)$$

Where  $y$  is the expected value,  $\hat{y}$  is the predicted value,  $\lambda$  is L2 regularization, and  $\theta$  is the parameter set of the neural network.

### 3. Experimental Analysis

The public data set of Twitter for aspect-level sentiment analysis is adopted. The length of

Twitter data set is only 16.3 words, and the maximum document length in the whole data set is only 41 words. Classification model training and testing: In this experiment, Twitter data is divided into 8:1:1 ratio, 4500 as training data set, 500 as development set and the last 500 as test set.

In the experiment, Python NLTK is used to pretreat the text with clauses and Tokenized. In the experiment, four-layer GCN is used, and Adam optimizer is used to train parameters with a learning rate of 0.001. The size of batch training is set to 128. In order to avoid over-fitting, dropout technology and early-stop technology are adopted. dropout is set to 0.2 and the maximum number of training rounds is 50.

The purpose of fine-grained emotion recognition experiment is to verify the accuracy of the attribute-oriented emotion recognition model proposed in this paper based on LSTM. In this experiment, 20,000 pieces of comment data were randomly extracted from all the comment texts as experimental corpus, and then they were labeled with emotional polarity (positive or negative), and divided into training set and test set according to the ratio of 4:1, and finally a fine-grained emotion recognition model was obtained by training. The indicators of the model are shown in Table 1:

Table 1 Performance of Fine-Grained Emotion Recognition Model

evaluating indicator	Index score
Precision	0.924
Recall	0.884
F1	0.907

The precision is 0.924, the recall rate is 0.884, and F1 is 0.907. It can be seen that the fine-grained emotion recognition model has good performance and can accurately identify the emotion polarity oriented to multi-layer attributes.

The experimental results of this algorithm and other comparative algorithms on the same data set are shown in Figure 3.

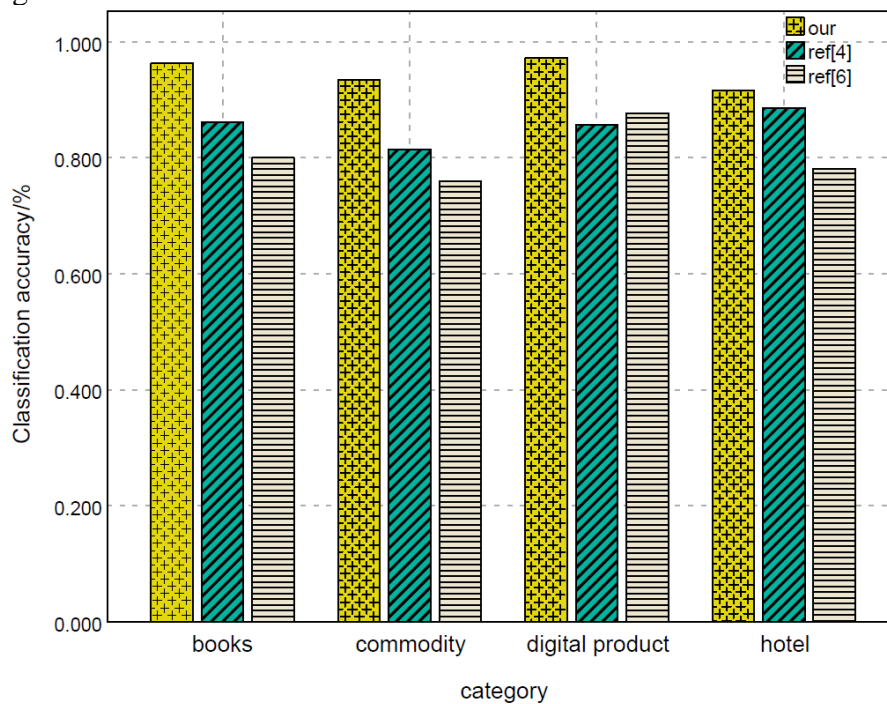

Fig.3 Comparison of Classification Accuracy of Three Models in Different Categories

The experimental results show that the classification accuracy of this method on Twitter data sets is higher than that of the comparison method, which fully proves the effectiveness of this algorithm.

The improved algorithm proposed in this paper has an accuracy rate of 90% in the recognition of four emotional tendency categories, which proves that the improved algorithm is feasible and simple to operate.

However, in this paper, when the dictionaries of different emotional tendency categories are unbalanced, they are simply normalized, while the discrimination results in this paper are given under the condition of balanced data, which will lead to inaccurate recognition results, which needs to be improved.

#### 4. Conclusions

Aspect-level sentiment analysis belongs to fine-grained sentiment analysis, which aims to predict the emotional polarity of a specific entity or aspect in a text, and its key lies in extracting text representation. The analysis of online comments based on sentence level and text level is the main task of traditional sentiment analysis, that is, coarse-grained sentiment analysis. In this paper, the application of LSTM neural network model in text emotion analysis and emotional word extraction is studied. A text sentiment analysis model based on LSTM neural network model is proposed, which consists of two parts: LSTM and GCN. The research results show that the accuracy of the improved algorithm proposed in this paper reaches 90% in the recognition of four emotional tendency categories, which proves the feasibility of the improved algorithm.

#### References

- [1] Huang F, Zhang X, Zhao Z, et al. *Image-text sentiment analysis via deep multimodal attentive fusion*. *Knowledge-Based Systems*, vol. 167, no. 1, pp. 26-37, 2019.
- [2] Bakar M, Idris N, Shuib L, et al. *Sentiment Analysis of Noisy Malay Text: State of Art, Challenges and Future Work*. *IEEE Access*, vol. 10, no. 99, pp. 1-1, 2020.
- [3] Nawaz A, Awan A A, Ali T, et al. *Product's behaviour recommendations using free text: an aspect based sentiment analysis approach*. *Cluster computing*, vol. 23, no. 2, pp. 23, 2020.
- [4] Jain A, Nandi B P, Gupta C, et al. *Senti-NSetPSO: large-sized document-level sentiment analysis using Neutrosophic Set and particle swarm optimization*. *Soft Computing*, vol. 24, no. 1, pp. 3-15, 2020.
- [5] Martins R, Almeida J J, Henriques P, et al. *A sentiment analysis approach to increase authorship identification*. *Expert Systems*, vol. 17, no. 2, pp. 12469, 2019.
- [6] Ma X, Zeng J, Peng L, et al. *Modeling multi-aspects within one opinionated sentence simultaneously for aspect-level sentiment analysis*. *Future generation computer systems*, vol. 93, no. 11, pp. 304-311, 2019.
- [7] Lu X, Zhang H. *Sentiment Analysis Method of Network Text Based on Improved AT-BiGRU Model*. *Scientific Programming*, vol. 2021, no. 12, pp. 1-11, 2021.
- [8] Long F, Zhou K, Ou W. *Sentiment Analysis of Text Based on Bidirectional LSTM with Multi-head Attention*. *IEEE Access*, vol. 66, no. 99, pp. 1-1, 2019.
- [9] Ahmad S R, Bakar A A, Yaaku M R. *Ant colony optimization for text feature selection in sentiment analysis*. *Intelligent Data Analysis*, vol. 23, no. 1, pp. 133-158, 2019.
- [10] Lee G T, Chang O K, Min S. *Semisupervised sentiment analysis method for online text reviews*. *Journal of Information Science*, vol. 47, no. 3, pp. 3, 2020.