

Design of Multi-Channel Temperature Acquisition System Based on STM32

Rui Pei^{1,*}, Yushuai Cao¹

¹*School of Mechanical Engineering, Anhui University of Science and Technology, Huainan, China*

**Corresponding author*

Keywords: Temperature acquisition, Temperature monitoring, STM32, DS18B20

Abstract: The change of electrolyte temperature in electrochemical machining results in the change of conductivity, and then affect the machining accuracy. A multi-channel temperature acquisition system based on STM32 was designed in order to monitor the temperature distribution in the process of processing, Adopting the structure of "Main Controller + Function Module", the acquisition module is composed of multiple DS18B20 temperature sensors, and the STM32F103RCT6 single chip microcomputer is used as the system control center to complete the temperature acquisition and storage, the precision of temperature data acquisition is improved significantly by digital filtering anti-interference processing. In order to verify the reliability and stability of the acquisition system, the temperature measurement and acquisition test is carried out. The test results show that the system has rapid response, strong operability and high acquisition accuracy.

1. Introduction

Electrochemical machining can significantly improve the physicochemical properties, machining precision and surface quality of electrochemical machining gap process. The constant temperature of the electrolyte is a necessary condition to ensure the normal process. During the process, the increase of the temperature of the electrolyte affects the conductivity and current efficiency of the processing area, at the same time, the continuous rise of the electrolyte temperature leads to the vaporization and boiling of the electrolyte in the processing gap, resulting in a significant increase in the bubble rate. When the bubble rate increases to a certain threshold, the flow field of the electrolyte may produce flow blockage, which seriously affects the stability of the processing[1]. Therefore, it is very important to measure the temperature of electrolyte in real time during machining.

The temperature distribution affects the workpiece forming, because the processing gap is small, the temperature is difficult to be measured directly, so the temperature in the electrolyte circulation system is detected, and most of the domestic electrolytic equipment is a single point temperature measurement method, and cannot grasp the real-time changes in the temperature value in the process of electrolytic processing[2]. If the method of manual direct temperature measurement is time-consuming and laborious, and the waste gas generated in the process of electrolyte heating, long time inhalation of harm to the operator's body.

Therefore, aiming at the above problems, a multi-channel temperature acquisition method based on STM32 is proposed in this paper. The STM32 MCU is used as the hardware control center, and

the digital DS18B20 temperature sensor is used to realize the collection, analysis and storage of temperature data in the electrolyte circulation system.

2. Structure Design of Temperature Acquisition System

The structure design of the multi-channel temperature acquisition system based on STM32 is shown in Figure 1. The system is composed of multiple DS18B20 temperature sensors to collect and convert temperature data into digital signals at the same time. The STM32 MCU processes and stores the signals, calculates the actual temperature values of each channel and displays them on the TFTLCD touch screen. A large amount of temperature data is collected during the detection process, and excessive use of Flash memory for storage may affect the running rate of STM32 microcontroller. Therefore, FATFS file management is used to store a large number of temperature data into MicroSD cards. Meanwhile, to ensure that the internal clock of STM32 microcontroller is not affected by the external temperature during work, Crystal oscillator circuit is used to solve the problem of clock frequency instability[3].

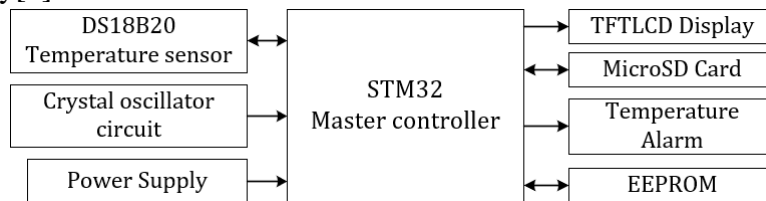

Figure 1: Structure design of STM32 multi-channel temperature acquisition system.

3. System Hardware Design

3.1 STM32 Main Control Module

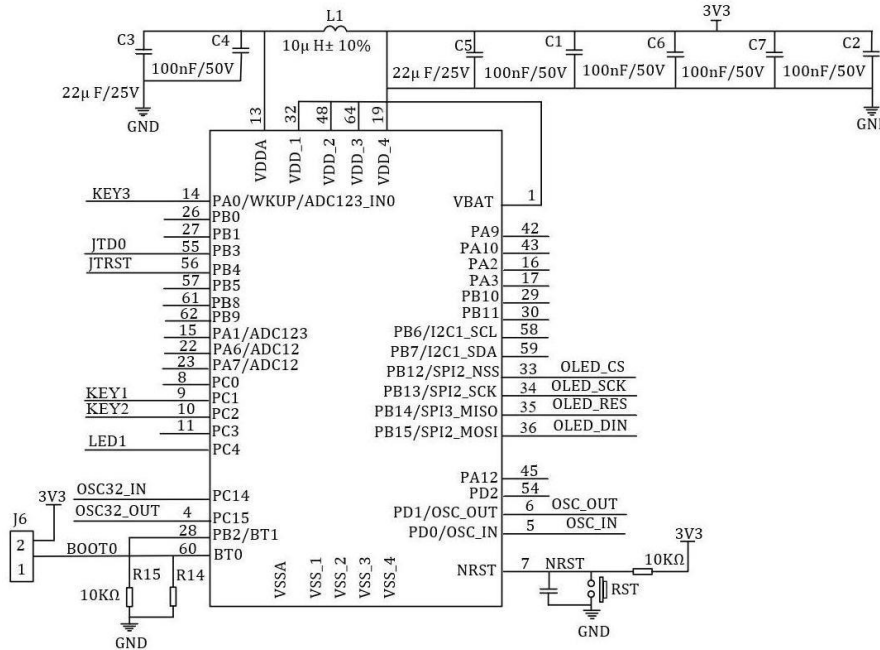

Figure 2: STM32 microcontroller circuit.

As an important part of the multi-channel temperature acquisition system, it is particularly important to select a controller with low power consumption and high running speed. Considering

the need to accurately realize the remote reading of temperature data, STM32F103RCT6 MCU launched by Semiconductor ST corporation as the control center, which just meets the design requirements. Using Cortex-M3 kernel ARM V7 architecture, it not only supports Thumb-2 instruction set, but also has 48kB SRAM, 51 universal I/O interfaces, 2 12-bit ADCs, 2 DMA, 5 serial ports, etc., fully satisfying the acquisition and storage of temperature[4].

The hardware circuit of STM32F103RCT6 MCU is mainly composed of filtering circuit, reset circuit, TFTLCD display circuit, etc., as shown in Figure 2. The general power network part produces high-frequency and low-frequency noise, which affects the signal accuracy of temperature data acquisition. Therefore, STM32F103RCT6 MCU has several sets of digital analog power-ground pins, namely VDDA and VSSA. Capacitors C1, C2, C6 and C7 can meet the stability requirements of the oscillator, and at the same time, they can filter out the high frequency noise signal of the digital power supply pin, and the low frequency noise of the analog power supply pin can be effectively filtered out through capacitor C3[5].

3.2 Power Conversion Circuit Module

All functional modules in the temperature acquisition system need the stable support of the power supply. The power supply conversion circuit equipped with the STM32F103RCT6 MCU can convert the input voltage from 5V to 3.3V, the continuous and stable power supply of the power supply module effectively guarantees the accuracy of the system's signal acquisition.

The power conversion circuit is shown in Figure 3, STM32F103RCT6 MCU voltage stabilized input terminal (Vin) power supply is about 4.6V, rather than 5V, the input terminal (Vout) can output 3.3V power supply voltage after voltage reduction by the power supply. The power network part of the single chip continuously provides stable 5V power supply voltage to the communication download module, and the diode (VD1) can produce a forward voltage difference, so as to ensure that the communication download module is not affected by the reverse power supply function, and ensure the normal transmission of data and control signals in the process of communication[6].

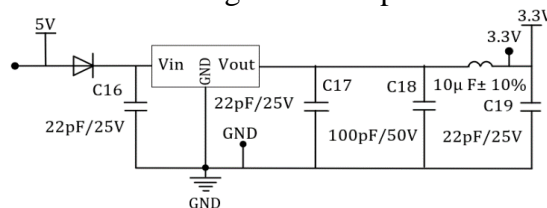

Figure 3: Power conversion circuit.

3.3 Temperature Sensor Module

The temperature sensor module is a new type of digital temperature sensor DS18B20 with simple interface and small size, which is introduced by DALLAS Semiconductor Company, the temperature range is $-55^{\circ}\text{C}\sim+125^{\circ}\text{C}$ [7]. Most of the temperature measuring components such as thermistors on the market do not have the function of directly reading the measured temperature value, and the DS18B20 temperature sensor can be built according to the requirements of actual working conditions through simple programming design sensor network. The principle of temperature measurement of the DS18B20 temperature sensor is shown in Figure 4, the pulse signal generated by the low temperature reading coefficient oscillator is transmitted to the counter. At this time, the pulse signal received is calculated by the counter, and the value of the temperature register is added by 1, the cryogenic counter stops working[8].

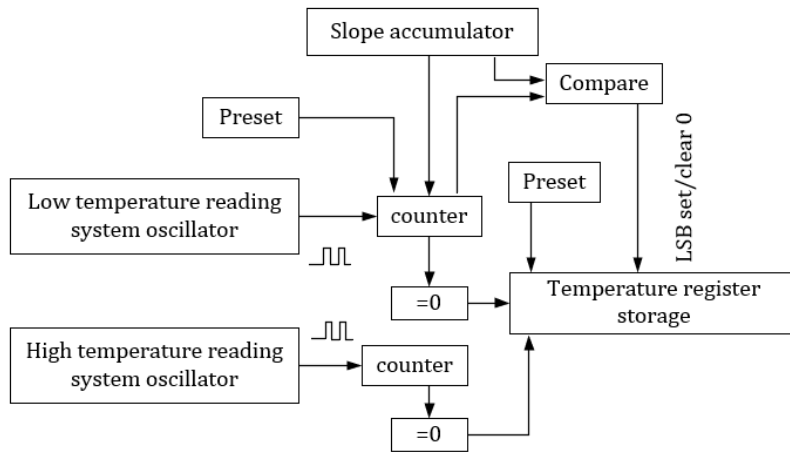

Figure 4: Principle of temperature measurement DS18B20.

4. System Software Design

4.1 Time Sequence Signal of DS18B20

In order to improve the anti-interference of the whole temperature acquisition system, the single bus communication mode of DS18B20 temperature sensor is used to transmit the control signal and data signal. Therefore, the data signal transmission process of the bus must strictly abide by the read and write standard protocol.

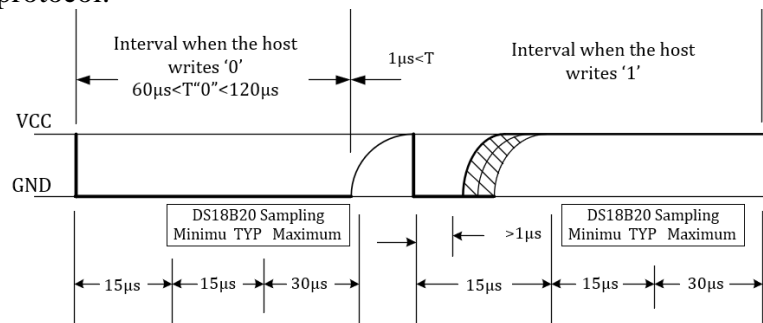

Figure 5: Write timing.

As is shown in Figure 5, when writing timing sequence, the master controller pulls the data line from high power level down to low level $15\mu\text{s}$ and then releases the bus. No matter writing 0 or 1, it must last at least $60\mu\text{s}$. The master controller initializes the write timing sequence, and DS18B20 temperature sensor detects that the data line level is pulled down and waits for $15\mu\text{s}$ to start collecting the I/O line timing sequence. During the sampling period, if the bus is at high power level, write 1, and the bus is at low power level, write 0, and leave at least $1\mu\text{s}$ recovery time between the two write timing signals on the data line, so as to ensure the integrity of the data collected by the DS18B20 temperature sensor[9].

The data is transmitted on the single bus by pulling the low level signal, releasing the single bus to restore the high level after $1\mu\text{s}$, the bus is pulled from the high level to the low level and keeps the low level for $1\mu\text{s}$, and then the bus is pulled high to generate the reading timing gap, the DS18B20 temperature sensor detects that the bus is pulled down by $1\mu\text{s}$ and begins to transmit data. After the completion of the reading sequence work, the bus is released within $60\sim 120\mu\text{s}$, in Figure 6. If the transmission is 0, the bus is pulled to the end of the low power flattening period; if the transmission is 1, the bus is released to the high level.

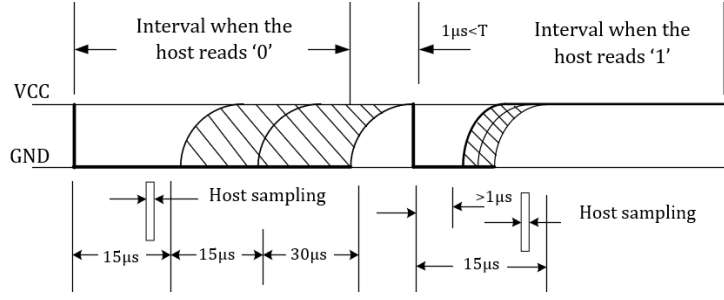

Figure 6: Read timing.

4.2 System Software Anti-Jamming Processing

In the process of designing the temperature acquisition system, we need to consider many factors, in addition to the selected acquisition module must meet the design requirements, but also consider the anti-interference and reliability of the system, especially in the process of electrochemical machining pulse power output current may cause electromagnetic interference to the main controller STM32F103RCT6 chip. In order to improve the sampling accuracy, filtering (median average filtering method) is implemented in the system operation to suppress interference.

(1) First Filter Processing

The value measured by the DS18B20 temperature sensor at the i time is set as $X_i (i=1 \sim N)$, and the serial number of temperature data values is written in a chronological increasing way[10].

Recursive arithmetic mean method:

$$Y_k = \frac{1}{N} \sum_{i=1}^N X_i \quad (1)$$

(2) The Second Filtering Process

Due to the large amount of temperature data collected, the average filtering method may lose the high-frequency component of the data and amplify the interference effect on the high amplitude. However, the average filtering method of the median value can effectively reduce the deviation of the signal caused by the occasional external pulse interference.

After removing the maximum Max value and minimum Min value from the collected temperature data, calculate the arithmetic mean value of the temperature data:

$$Y_k = \frac{1}{N_1 - 2} \sum_{i=2}^{N_1-1} (X_i - X_{max} - X_{min}) \quad (2)$$

(3) The Third Filter Processing.

By rewriting the digital filter program, multiple temperature acquisition channels share one filter program, which effectively avoids the CPU's misjudgment of temperature acquisition values. In order to further improve the stability of the temperature acquisition system, recursive quadratic average filtering is performed.

The final temperature measured value is obtained after transformation:

$$H_k = \frac{1}{N_1} \sum_{i=2}^{N_2-1} Y_i \quad (3)$$

In the actual data acquisition, in order to speed up the operation, it is generally appropriate to select 3~16 when N value is not too large. The data acquisition and filtering process is shown in Figure 7.

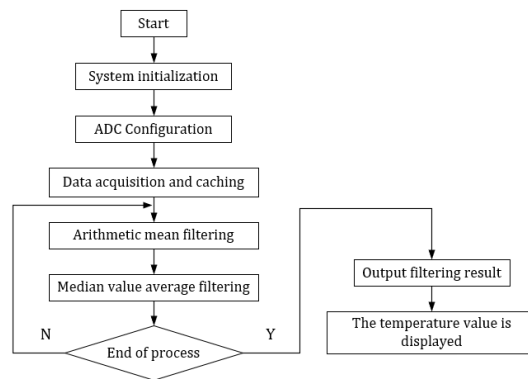

Figure 7: Temperature data filtering process design.

5. Test the Temperature Acquisition System

In order to test the feasibility of the design of the temperature acquisition system and the stability of the running state of various functions, the actual temperature measurement and acquisition experiment was carried out. After the system test, Origin software was used to draw the original temperature data curve of each channel in Figure 8. It can be seen that, in the actual processing process, the system is interfered by accidental external factors in the environment, resulting in pulse peaks in the temperature curve.

As is shown in Figure 9, in order to improve the reliability of the developed temperature detection platform for data acquisition, which after signal amplification, A/D conversion and digital filtering algorithm processing. The pulse peak is effectively filtered out, and the trend and peak characteristics of the original temperature data curve are well preserved, with good curve smoothness and no signal loss and data distortion.

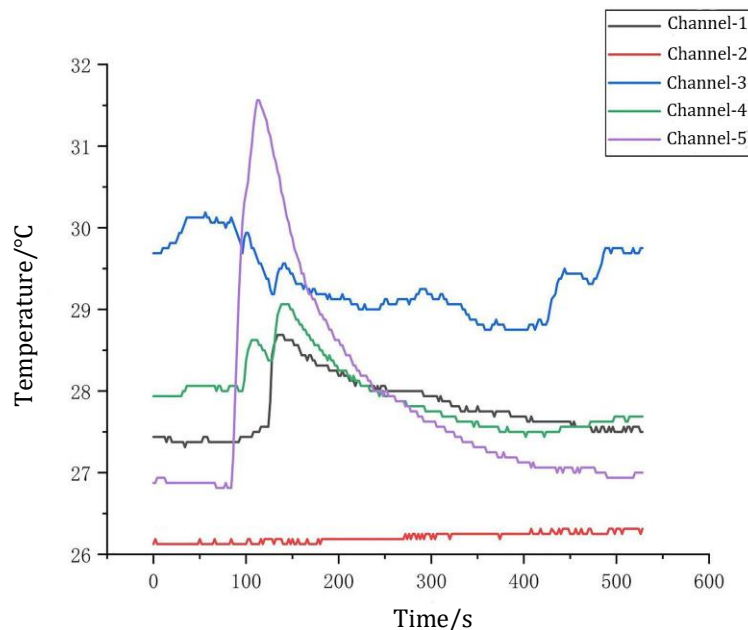

Figure 8: Raw temperature data curve.

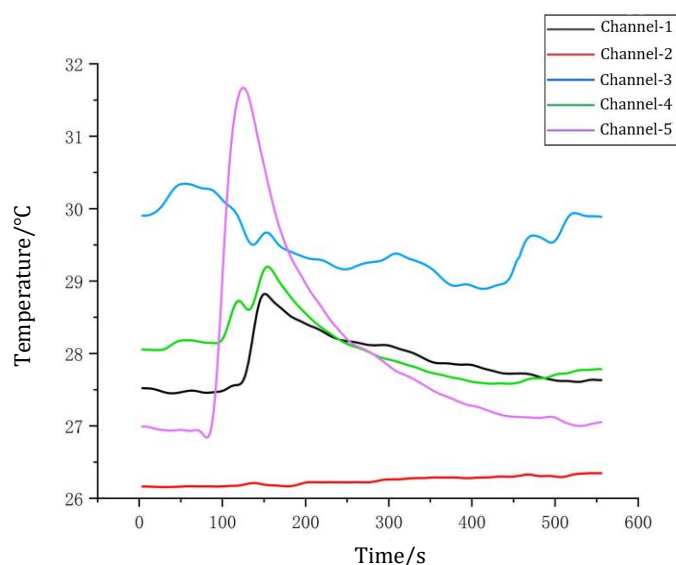

Figure 9: The temperature data curve after filtering.

6. Conclusion

In this paper, a design scheme of multi-channel temperature detection system is proposed. With STM32F103RCT6 MCU and DS18B20 temperature sensor as the main hardware, the software development and hardware design of the system are completed, and the temperature collection test is carried out in the electrolyte circulation system. It is verified that the designed temperature acquisition system has the characteristics of simple operation, good stability and high degree of automation, and can meet the requirements of multi-channel temperature data detection in the complex electrochemical machining environment.

References

- [1] Pei Di. *Research on Temperature Domain of Pulsed Electrochemical Machining Based on Multi-field Coupling Simulation* [D]. Hefei: Hefei University of Technology, 2017:3-15.
- [2] Chang Yuanyuan, Fan Zhijian, Tian Junwei. *Multi-channel Temperature Detection System for Electrolytic Pool in Electrochemical Machining* [J]. *Instrument Technique and Sensor*, 2013(02): 55-57, 82.
- [3] Shen Jianliang, Jia Yukun et al. *Introduction and Improvement of STM32F10x Series ARM Micro Controllers* [M]. Beijing: Beihang University Press, 2013: 30-75.
- [4] Suo Yuntian, Liang Longxue, Lin Chongfen. *Design of multi-point temperature acquisition System based on STM32* [J]. *Journal of Lanzhou Jiaotong University*, 2013, 32(6):60-62, 81.
- [5] Bian Qianyu. *Design and Implementation of an Automatic Monitoring System for Thermal Stability Test* [D]. Harbin: Harbin University of Science and Technology, 2021: 30-58.
- [6] Jia Danping, Gui Jun. *STM32F103x Microcontroller and Operating system μ C/OS-II Operating System* [M]. Beijing: Publishing House of Electronics Industry, 2017: 90-110.
- [7] Song Quan, Xie Songhua, Wang Chao et al. *Temperature Acquisition and Analysis System based on Single Chip Microcomputer and DS18B20* [J]. *Electronic Science and Technology*, 2015, 28(9):100-103.
- [8] Tang Kaijie, Li Can, Wang Di et al. *Design of Digital Temperature Acquisition and Alarm System based on DS18B20* [J]. *Sensors and Microsystems*, 2014, 33(3):99-102.
- [9] Wang Wen. *Temperature monitoring system based on ARM and DS18B20* [D]. Zhenjiang: Jiangsu University of Science and Technology, 2012: 25-37.
- [10] Wen Changbao, Gao Lihong, Fang Jishan et al. *Research on High Precision Weighing System Based on Improved Amplitude Limiting Average Filtering Method* [J]. *Journal of Sensing Technology*, 2014, 27(5):649-653.