

Fully Using Wood and “Retreat”: The Generation and Solution of the Errors of Wooden Components in the Stilted Building of Tujia Nationality

Keqiang Chen, Jian Yang*, Jiaxiong Liu

School of Architecture and Art Design, Hunan University of Science and Technology, Xiangtan, Hunan, China

**Corresponding author*

Keywords: Tujia ethnic, stilted building, borrow ink, fully using wood, retreat

Abstract: Irregular wood is a common problem for craftsmen engaged in wooden buildings, and the resulting errors always affect the production and installation of components. Through “fully using wood” and “retreat” processing methods, the palm ink master not only meets the construction requirements of non-specific specifications of wooden buildings, but also solves the error problem of wooden frame installation caused by wood size and bending. This paper takes Mr. Liu Anxi's new Tujia stilted building project as the research object, records the whole process of component processing, and introduces in detail Mr. Liu Anxi's two component production techniques of “fully using wood” and “retreat” in dealing with various types of wood. Through the analysis of the principle and process of these two techniques, it is intended to understand the artisanship thinking and consciousness in the production and construction of craftsmen and explore the practice mechanism of the palm ink master to reduce component errors.

1. Introduction

In the summer of 2021, the author carried out a 65-day follow-up survey on the construction process of Liu Anxi's new Tujia stilted building project (Figure 1). The whole project has four floors. The main part of the first to third floors is a traditional wooden house. The fourth floor is a “Cuojikou” (the plane form is “” type) type stilted building with a total height of 9.25 meters, which is the highest in Lichuan [1]. This new form of Tujia wooden architecture is also the innovation of Master Liu Anxi. The survey found that: in the production process of large wood components, a large number of bent columns and short beams are used, and almost all the components were hand-made. There were only three kinds of measuring tools: flat ruler, bent ruler and rolled ruler. The components are complicated, and the errors are everywhere. To ensure the smooth installation of columns and components, how to solve these errors has become the focus of the component production process. This paper is a case study, based on detailed data records, from the perspectives of the construction process and the rule of ruler method, it analyzes the two types of component fabrication techniques of “fully using wood” and “retreat” for the bending of the column, and strive to the mechanism of reducing the component error of the palm ink master.



Figure 1: The wooden frame of Tujia Stilted Building

2. Fully Using Wood

“Large materials are used for great use, and small materials are used for small use” is the principle of material selection followed by the palm ink master of Tujia stilted building. It is necessary to make the best use of materials according to their materials. The timber for building houses of Tujia nationality in Lichuan area is usually Chinese fir [*Cunninghamia lanceolata* (Lamb) Hook]. Chinese fir is fast-growing, straight, and full trunk, high utilization rate, and different parts can be divided into different building components. Generally, the lower part of Chinese fir is used as columns, the middle part as purlins, and the top part as rafters [2]. Master in the forest farm according to the size of the house specification selection of Chinese fir, after rough processing to the site. The wood selected by the palm ink master is generally regular, coarse, and thin, and the bending is easy to control. If the building materials are provided by the owner, the wood situation is complex, old materials, bending materials often appear, although such wood can be used for construction, the processing process is complex.

In wood processing, the palm ink master selects the material location and designs the mortise and tenon joint size according to the material principle and processes the components. and processes the components to ensure the smooth installation of each component when the house is erected. Making full use of wood throughout the construction process of the stilted building will directly affect the difficulty of housing installation, which is one of the most critical technologies in the production process of Tujia stilted building.

2.1 Fully Using Wood of Laying-Out

Bending wood is what all craftsmen will meet, the palm ink master reduces the error between components as much as possible by painting ink and borrowing ink to ensure that the housing erection stage can be carried out smoothly. This project is a residential house. To save wood and construction cost, Master Liu Anxi usually makes full use of bent wood to make columns, and uses many “edge materials” (rather than “core materials”) to process *Fangzi*. In the rough processing of wood, the craftsmen will make trade-offs according to the bending direction of wood to determine the cross and middle ink, which depends on the accumulation of craftsman experience. The position of middle ink needs to be carefully considered and balanced repeatedly to save working hours and materials. During column processing, the bending material should be straightened as far as possible to minimize the bending degree. The specific method is to trim the convex part in the middle, and both ends of the concave side and straighten the column to the maximum extent [3].

After rough processing of wood, it is also necessary to “borrow ink” to solve the error between each column, so that the mortises of each column are on the same line as much as possible. Borrowing ink is the practice of shifting the center line of the column in the opposite direction of the bending, and the position of the mortises are also slightly adjusted according to the position of the middle ink. The amount of borrowed ink depends on the degree of bending of the column. If the bending degree of the column is small, it borrows 3 to 5 points (unit of length, equivalent to 3.33 millimeter) in the reverse direction of the bending. If the bending degree of the column is large, it borrows 7 points in the reverse direction of the bending, without a certain rule.

When drawing the cross-ink, the eyes should be level with the flat surface of the column, and the bending direction of the wood should be observed. If the overall bending direction of the wood is to the right, the vertical ink will be shifted to the left, and the offset distance only needs to be seen from the bottom of the column, divide the flat surface of the column into two parts of equal size on both sides. When drawing horizontal ink, if the column only bends in one direction, then choose the midpoint of vertical ink to draw horizontal ink. But most of the columns are not only bending in a direction, which requires repeated vertical ink operation steps to draw horizontal ink (Figure 2). Therefore, the midpoint of the cross-ink is mostly not the geometric center of the end, but changes according to the wood situation. Connecting the bottom of the column with the top of the cross-ink is the middle ink of the column, and the painting ink of the mortise is determined by the position of the middle ink.



Figure 2: Steps of drawing cross ink

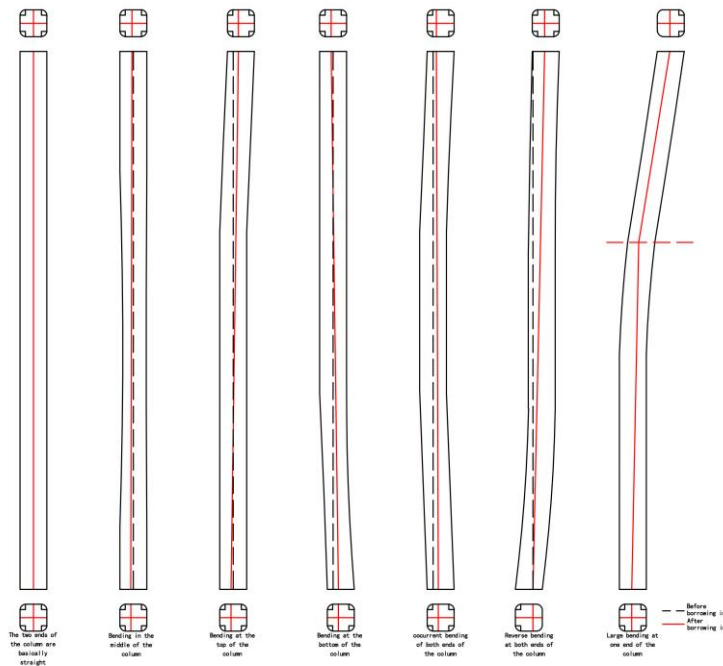

Figure 3: Law of borrowing ink

Basic straight wood, after drawing cross-ink at both ends, connecting the cross-ink at both ends, you can get four verticals to the ground cylinder ink; for wood with small bending degree, the cross-ink at both ends of the column needs to shift to the reverse direction according to the bending degree of wood, and the middle ink is not a straight line perpendicular to the ground; wood overbending, two ends of the cross-ink connection, there will be a part of the ink line is not on the column, this time you need to draw two middle inks. The procedure of two middle inks is: 1) Horizontal auxiliary line at maximum bending; 2) Treat the lower column as a straight column, do the middle ink of this column; 3) Draw the second middle ink by treating the curved end regarded as a column with a smaller curvature (Figure 3). It should be noted that this bending can only occur in the depth direction, on the one hand, to ensure that the center line of wood is in a straight line, which is convenient for the installation of the batten wall; on the other hand, it is to ensure the smooth installation of the *Chuanfang* (component between connecting column and column in depth direction of building), to prevent the column deformation due to force, affect the stability of the structure [4].

2.2 Fully Using Wood of *Chuanfang*

In the traditional construction process, the palm ink master generally first check wood size and specifications, and then determines the size of the mortise-tenon. Of course, the situation of painting ink first and then checking wood sometimes occurs. The size of wood transported from the forest factory is similar to the design size, but it is also different. The size of *Fang* is large or small, and the length is long or short. The palm ink master will select the wood that has little difference according to the design size of *Fang*, and then determine the interface of *Chuanfang* according to the length of wood. The size of *Fang* is large and small, long and short. According to the design size of the *Fang* material, the palm ink master will select the wood with little difference, and then determine the interface of the *Fang* according to the length of the wood (In general, *Chuanfang* is made of complete wood. The appearance of the interface is a craftsman's flexible approach to a slightly shorter timber without affecting the overall structural stability; at the same time, the use of short materials will also reduce the difficulty of installation and accelerate the construction progress.).

When making components, the palm ink master will adjust the mortise-tenon size at any time according to the wood condition, which leads to the measurement size often different from the design size. The palm ink master explained that *Fang*'s actual size is usually larger than the design size. In order to ensure the integrity of the wood and reduce the workload of excavation, the mortise-tenon size on the column is usually increased. If the actual *Chuanfang* size of 3-5 points larger than the design size, the original *Chuanfang* mortise up 3-5 points, and do 1 cun (unit of length, equivalent to 3.33 centimeter) deep shoulder tenon. If the actual size of *Chuanfang* is more than 5 points larger than the design size, the original mortise of *Chuanfang* will be opened up. At this time, the mortise of *Chuanfang* and the mortise of *Doufang* (The bay direction of the house is used to connect components between each row of columns) will intersect. In order to ensure that the *Doufang* can pass through the mortise smoothly, the palm ink master will open a square opening on the *Chuanfang*. The size of the opening is generally 1-2 points larger than that of the *Doufang*, which is convenient for the installation of large wooden components. Or through the *Chuanfang*'s mortise, the *Doufang*'s mortise is made into the form of palm tenon and shoulder tenon, forming a form of overlapping each other (Figure 4).

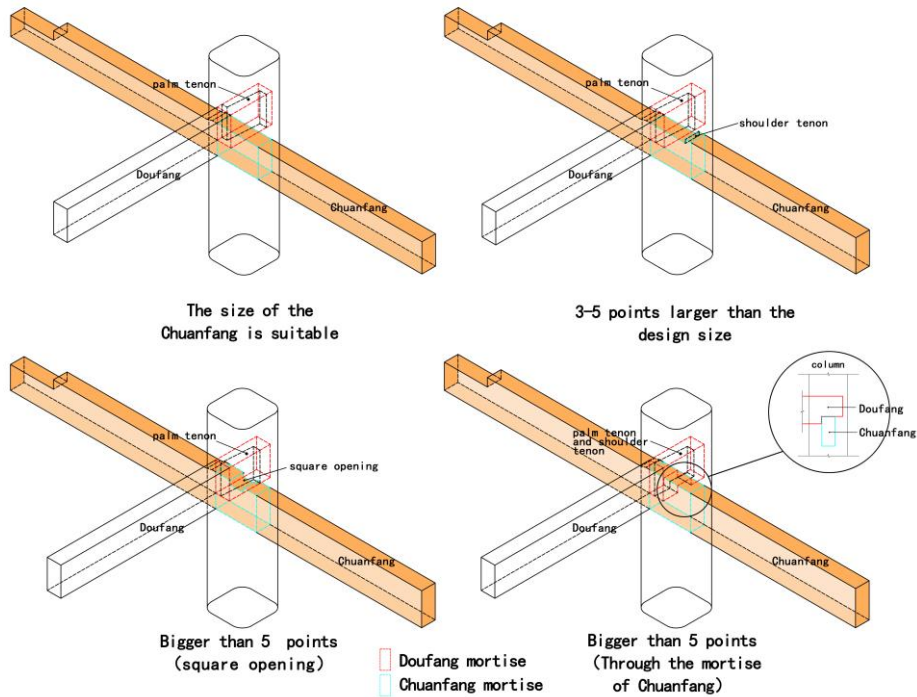

Figure 4: Practice of actual size exceeding design size of *Chuanfang*

2.3 Fully Using Wood of *Doufang*

Doufang connects two columns, bearing floor, is the main bearing member. *Doufang* is divided into square material and round material. Square material is the processed cuboid wood. This kind of wood is relatively large, and is often used for *Zhaomianfang* (the transverse *Fang* above the door and window). Round material is the rough processed round wood, playing a major role in bearing capacity [5]. Round processing, need to cut the lower two corners of wood into an arc. The upper part of the round material is planed into a flat plane by electricity, which is convenient to set aside the floor slab. After the wood processing is completed, the upper part is flat and the lower part is round, which is similar to the stalk of sesame, and is commonly known as “sesame stalk”. After the round material is processed, the craftsman will do “*Daohao*” (Figure 5) before the mortise-tenon of *Doufang*. That is, in front of the mortise and tenon on both sides of the vertical plane 2.0 ~ 2.5 cun cut off part, depth of about 2 points, made into arc. The surface of the column after “*Daohao*” is curved, and there is no gap at the junction with the column, so the transition is natural.

In the design of this Tujia stilted building, Liu Anxi adjusted the height of the column under the condition of meeting the force of the column, and made some changes to the timber frame. As a result, some columns did not reach the top of the building, so there was no *Doufang's* mortise on the column. In order to stabilize the overall structure, the palm ink master will use the method of “shelving the floor pillow”, that is, they still add the *Doufang* here, but only one end of the *Doufang* is made in the form of sesame stalk, and it is not processed. It is directly placed on the top of the *Chuanfang* on this layer, and the same row of *Doufang* with dovetail Joint connection (Figure 6).



Figure 5: Daohao



Figure 6: Dovetail Joint

2.4 The Principle of “Retreat and Concession”

The overlap between *Chuanfang* and *Doufang* is the special feature of this project. When the *Chuanfang* or *Doufang* material increases, the *Chuanfang* and *Doufang* mortises on the column will conflict with each other, so it is necessary to consider the structural treatment of the *Chuanfang* and *Doufang* conflicting with each other. At the beginning of the design, Mr. Liu Anxi has taken into account these problems and adopted the method of mutual “retreat and concession” to solve the conflict between *Chuanfang* and *Doufang*.

When making a measuring rod, Liu Anxi, the palm ink master, will make a preliminary estimation of the width of the *Chuanfang* and the *Doufang* according to the size of the wood. For example, the design width of the *Doufang* is 4.1 cun, and the design width of the *Chuanfang* is 4.2 cun (Figure 7), then this width range is 8.3 cun. The increase and retreat of the *Doufang* and *Chuanfang* must be completed within 8.3 cun. With 4 points for the limit, if the actual width of the *Chuanfang* is more than 4 points larger than the design width, the *Chuanfang* should borrow ink from the *Doufang*, and do the shoulder tenon. The amount of borrowing ink depends on the difference between the actual width and the design width (Figure 8). If the actual width is less than 4 points larger than the design width (including 4 points). At this time, *Doufang* does not need to borrow ink from the *Chuanfang*, and the mortise needs to be large in and small out (the width of the inlet column mortise is 2 points larger than that of the outlet column mortise, and the thickness is 1 point larger) (Figure 9) [6].

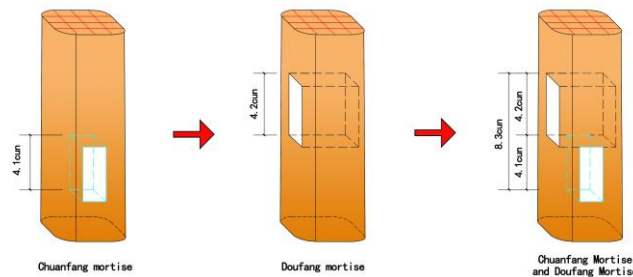

Figure 7: The schematic diagram of position and size of *Chuanfang* and *Doufang*

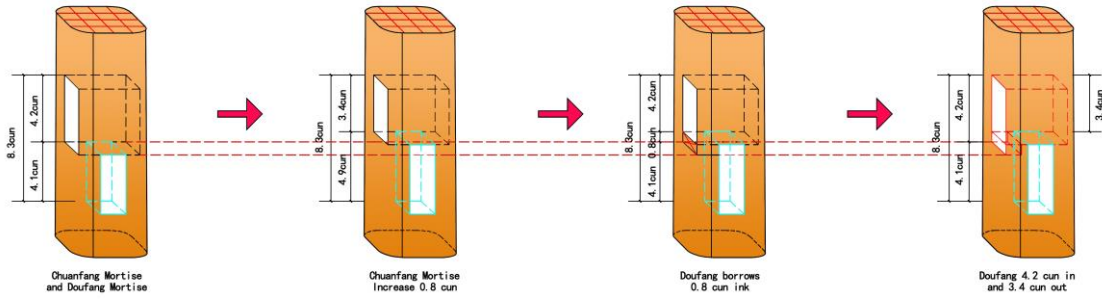

Figure 8: The practice that the actual width of *Chuanfang* is more than 4 points wider than the design width

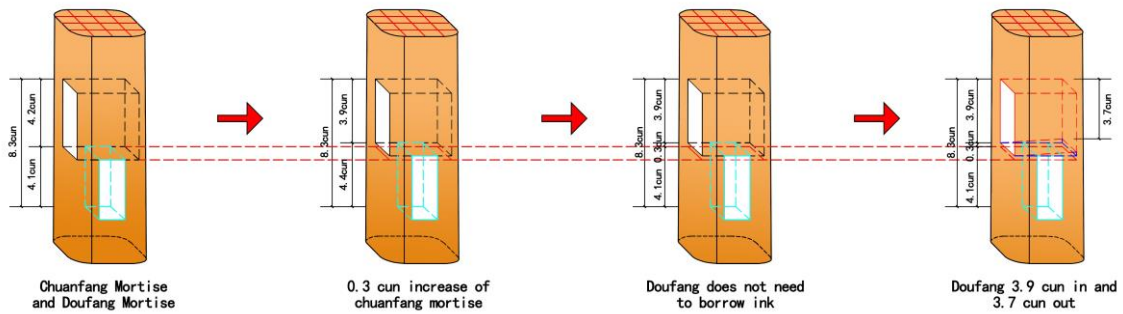

Figure 9: The practice that the actual width of *Chuanfang* is less than 4 points wider than the design width

Doufang borrow ink to make shoulder tenon and *Chuanfang* make a square opening are two methods in one form, all in order to ensure the stability of the structure under the condition of making *Chuanfang* and *Dou Fang* better through the mortise, to ensure the possibility of building. *Doufang* borrow ink is a traditional way, and *Chuanfang* to make square openings is a folk practice of saving labor evolved by master Liu Anxi through long-term practical experience. On the one hand, it reduces the workload of craftsman and maintains the integrity of wood; On the other hand, to prevent *Chuanfang* material too large, *Doufang* borrow ink as the shoulder tenon, the shoulder tenon is large and the connection part is too small, cannot guarantee the overall stability of the wooden frame.

3. Retreat

In the construction process of the stilted building of Tujia nationality, the steps of the palm ink master recording the mortise and tenon size on a specific tool —— “sign stick” (Figure 10) are called “down-retreat”, the process of transitioning the size of the sign stick to the *Fang* material is called “up-retreat” [7].



Figure 10: Sign stick

The process of down-retreat and up-retreat is the top priority of the whole production stage. The error of large wooden components is not affecting the whole when processing, but it must be accurate in size when making mortise-tenon. At this point you need a sign stick as a transition tool to record mortise size. The sign stick is a rectangular wood, which is used to carry the information of the mortise. The sizes of each part are marked with different symbols, and the corresponding names are written on the sign stick for later proofread. A sign stick can record eight mortise sizes at most when the size is appropriate [8].

The sign stick is not only used as a transition tool, but also as a special “drawing” to provide reference for later inspection and correction of mortise. In the process of component processing, the craftsman inevitably produces errors. If the *Fang* material is made according to the size of drawing ink, it will be difficult to install and increase the difficulty of construction due to the size mismatch. After the mortise is formed, the size of the mortise is measured to minimize the error caused by the processing and bring convenience to the installation. At the same time, the palm ink master used the way of “retreat” (the width and thickness of the *Fang* material gradually decreased) to further facilitate the installation of the frame.

3.1 Retreat of *Chuanfang*

Chuanfang through multiple columns, craftsmen need to use hammers and other tools to punch through *Fang* into the column, installation is quite difficult [9]. This requires the production of component mortise-tenon should pay attention to loose moderately, neither too loose to lose node structure function, nor too tight to bring difficulties to installation. Liu Anxi adopts the method of “retreat” to reduce the width and thickness of *Chuanfang* in different degrees. On the one hand, “small (material) to find large (mortise)”, the installation of components easier alignment mortise; on the other hand, the friction between the components and the mortise is reduced properly, which is convenient for installation.

The basic law of “retreat” is: With the middle column as the standard, the lower surface of the *Chuanfang* unchanged in width; on the basis of the original size, the upper surface is retreat 2 points at 2.5 cm after each through of a column mortise (Figure 11). In thickness, the mountain row component toward the outside side and the middle row component toward the hall side remains unchanged; on the other side on the basis of the original size, each through a column mortise 2.5 cm after retreat 1 point [10]. However, if the depth of the house is too large and the length of the *Chuanfang* is not enough, it needs to be connected with palm tenon and fixed with wood bolt. At this point in order to maintain the structural stability *Chuanfang*, “retreat” skips here, in the next mortise before the mouth 2.5 cm width retreat 2 points, thickness retreat 1 point.

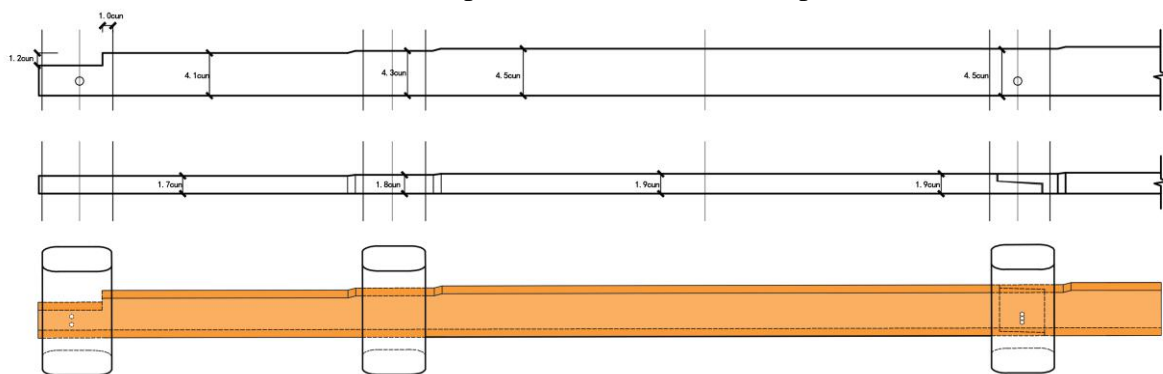

Above: Front view; middle: Top view; below: Axonometric drawing

Figure 11: Retreat of *Chuanfang*

3.2 Retreat of Doufang

Doufang spans a bay, connects two columns, supports the floor, and plays a major load-bearing role. There are generally no columns between the adjacent two rows of columns, so the *Doufang* only needs to process the two ends into tenon form.

If a *pick column* (between the two rows of columns, it is used to support jetting out the *Fangzi*) is added between the adjacent two rows of column, there are three treatment methods of *Doufang*: 1) The width of the mortise of the *Doufang* on the *pick column* is less than 2 points larger than that of the mortise at the port (Figure 12). 2) If the width of the mortise of the *pick column* is more than 2 points wider than that of the mortise at the port, the width “retreat” 2 points and the thickness “retreat” 1 points are made after passing 2.5 cm of the mortise of the *pick column*. But in order to save material and reduce workload, craftsmen usually do “retreat” at 2.5 cm ahead of the column edge (Figure 13). 3) When the *pick column* does not pass through the *Doufang*, no matter how big the *Doufang*, just do the groove suitable for the size of the *pick column* mortise, *pick column* directly stuck on the *Doufang*, the structure is relatively stable (Figure 14).

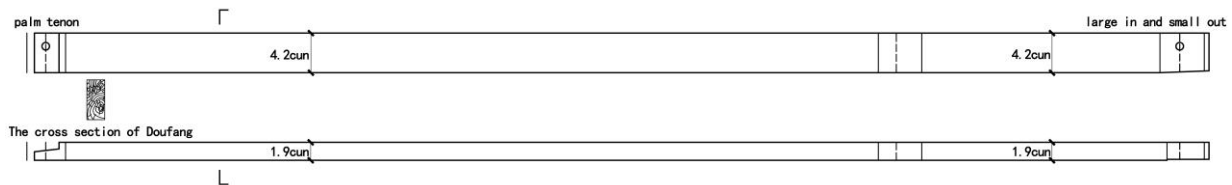

Figure 12: Doufang at both ends' “retreat” (Above: Front view; below: Top view)

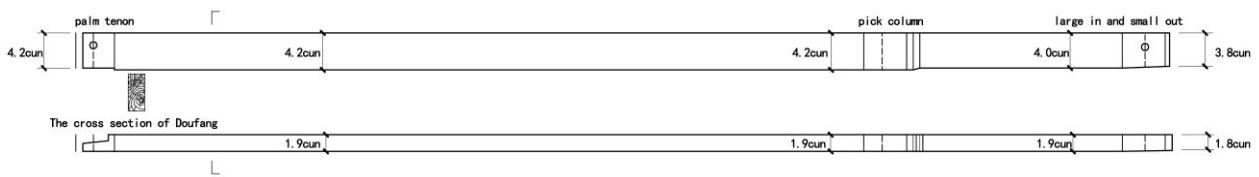

Figure 13: “Retreat” at the pick column of *Doufang* (Above: Front view; below: Top view)



Above: Front view; middle: Top view; below: Axonometric drawing

Figure 14: Pick column directly stuck on the *Doufang*

4. Conclusion

The big wooden components of Tujia stilted building are made by craftsmen by hand, and the error is inevitable. Controlling the error within a suitable range is one of the most important issues for the palm ink master. The error produced in the process of making large wooden components mostly comes from irregular wood and different processing methods of craftsmen. The Tujia craftsmen

created a unique processing method to reduce the error according to the wood specifications in the construction of the stilted building, and successfully applied it in the construction activities of the stilted building. This method not only meets the construction requirements of non-specific specifications of wooden buildings, but also solves the error problem of wooden frame installation caused by wood size and bending. The palm ink master solves the problem of using different specifications of wood in building construction through “fully using wood”, and achieves the purpose of saving material; passes the mortise information through the sign stick back and up, and solves the problem of dimension error of *Fang* material. At the same time, the sign stick is also a reference for later detection and calibration; solves the problem of component installation by “retreat”, reduces the friction between components, and facilitates the erection of the house.

Through participating in the construction practice, the immaterial construction experience and skills inherited orally by Tujia palm ink masters are obtained from the construction process. It can be found that there are not only regional ancient practices, but also the improvement methods made by craftsmen combined with factors such as labor, cost and materials. In the face of the loss of traditional construction techniques, it is hoped that this paper can provide some reference for the inheritance and development of traditional big wood construction techniques.

Acknowledgement

This research was supported by national social science fund of China (Grant No. 20VJXG024)

References

- [1] Kui Zhao, William L. Tilson, Dan Zhu. *Architectural Features of Stilted Buildings of the Tujia People: A Case Study of Ancient Buildings in the Peng Family Village in Western Hubei Province, China*. *Journal of Building Construction and Planning Research*, 2013, 1 (4).
- [2] Zhen Li. *Application of Chinese fir in ancient architectural practice*. *Traditional Chinese Architecture and Gardens*, 2002, (1): 58-60
- [3] Hanquan Guo. *Woodworking Technology of Ancient Buildings in Jiangnan*. *China building industry press*, 2014: 20-21.
- [4] Yun Zhao. *Huamo (ink-marking) and Taoqian (mortise-probing) in Vernacular Sichuan Architecture*. *Study on Natural and Cultural Heritage*, 2017, 2 (2): 141-147
- [5] Jiantian Li. *Research on the Construction Technology of the Master Carpenter Liu Anxi in Lichuan*. *Hunan University of Science and Technology, Xiangtan*, 2021, 49-50.
- [6] Jiaxiong Liu. *Record of construction skills of Lichuan carpenter Liu Anxi Wang house project*. *Hunan University of Science and Technology, Xiangtan*, 2022, 135-138.
- [7] Qingmi Shi, Ni Ni, Qian Zhang. *Core Technology and Space Culture Interpretation of Tujia Stilted Building*. *Forward Position*, 2015, (6): 109-116.
- [8] Guihua Li, Hengyu Zhao. *Interpretation of the Construction Skills of Tujia Hanging Feet Building and Big Wood—Take the Technical Essentials such as Haogan, Taotui and so on as an Example*. *Architecture & Culture*, 2019, (12): 248-249.
- [9] Liang Zhou. *Study on Tujia folk houses and its traditional Architecture Technology in the Southeast of Chongqing*. *Chongqing University, Chongqing*, 2005, 109-110.
- [10] Siliang Chen. *Research on Column-and-tie of Tujia Stilted Buildings in Western Hubei Province*. *Architectural Journal*, 2020, (S1): 103-108.