

The Working Principle and Parameter Design Method of Cycloidal Pinwheel Reducer

Yulin Lai*

State Key Laboratory of Oil and Gas Reservoir Geology and Exploitation, Southwest Petroleum University, Chengdu, 61000, Sichuan, China

867465353@qq.com

**Corresponding author*

Keywords: Transmission, Planet—Cycloid Reducer, Cycloid, Reduc

Abstract: The unique stability of cycloidal pin gear reducer can replace many impact transmission mechanisms to play a stable transmission role. Its characteristics are as follows: small quality, long life and easy maintenance. The cycloid reducer is a new type of deceleration equipment, which uses the basic principle of small tooth difference and large planetary transmission system. It can be widely used in manufacturing as a drive or deceleration device. The cycloidal pin gear reducer of the design scheme considers the dynamic model and design criteria, such as stable operation, load sharing of multi-tooth gear transmission and gearbox gear, to maintain high transmission efficiency and high load-bearing capacity. And it is very easy to manufacture. The cycloidal pin gear reducer used in this design has the advantage of simple design method. We can see from the analysis results that the performance index of the bearing is also fully in accordance with the use regulations. In this paper, the research paper discusses the following aspects of the pin wheel output pin-oscillating planetary transmission: First, the traditional method of designing the basic parameters of the pin wheel output pin-oscillating planetary transmission key components is referred to Design and calculation of basic parameters of planetary transmission. Second, the force calculation and analysis of the transmission system including the load of the support bearing and the arm bearing. Third, the final assembly drawings and key parts drawings are drawn using drawing software. Fourth, improve the life calculation and strength check of key parts and bearings such as studs and cycloid wheels.

1. Working Principle, Transmission Performance and Structural Performance of Cycloidal Pinwheel Reducer

It is a new type of meshing transmission mechanism, which adopts the K-H-V involute planetary transmission technology with small tooth difference. It can be said that it has been widely used in various production fields and engineering machinery fields[1-2]on a large scale, and generally acts as a driving and reducing device.

1.1. Structure and Transmission Characteristics of Cycloidal Pinwheel Reducer

The key of cycloidal pinwheel reducer consists of four parts:

(1) Rotating arm: The rotating arm consists of an input shaft and an eccentric sleeve.

(2) Cycloid wheel: The tooth form of the rotating wheel disc is the distance curve of the short distance outside the rotating wheel. In order to balance the input shaft and improve the load capacity of the transmission system, two eccentric cylindrical roller bearings are installed between the cycloid gear[3].

(3) Pin wheel: it is fixed on the pin gear housing by a pin gear pin, and a rotatable pin gear sleeve is installed on the pin gear pin, in order to reduce the friction and wear between the needle gear pin and the cycloid wheel

The output mechanism W is composed of a plurality of column pin shafts arranged on the output shaft and a column pin sleeve sleeved on the cantilever of the output mechanism W and is inserted into a pin hole of the cycloidal wheel together

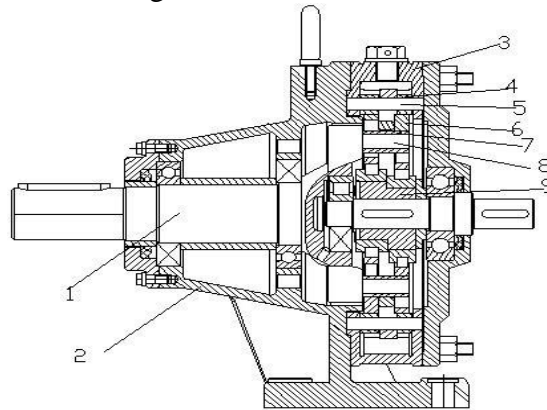

1. Output shaft 2. Frame 3. Pin tooth housing 4. Needle gear sleeve 5. Pin and gear pin 6. Cycloid wheel
7. Pin Sleeve 8. Pin 9. Eccentric wheel

Figure 1: Basic structure of cycloidal pinwheel reducer

1.2. The Meshing Principle of Cycloidal Pinwheel Drive

Compared with the helical cylindrical gear transmission of the ordinary reducer, the structure of the cycloidal pinwheel reducer is different: its tooth profile is composed of cycloids (not involutes)[4]. The concept is as follows: Cycloid: Cycloid is the trajectory of a moving circle when a curve (baseline) of a moving circle is purely rolling.

Flat cycloid: When the base line is a straight line, it is a flat cycloid or a variable cycloid.

Hypocycloid: a hypocycloid or luffing hypocycloid when the base line is pure rolling in a fixed circle.

Epicycloid: When the base line is a circle and makes pure rolling in the moving circle, the two circles are tangent, then it is an epicycloid or variable amplitude epicycloid.

Where: K is the factor of the amplitude variation

A is the length of the circumscribed epicycloid swing link

R_2 is the radius of the circumscribed epicycloid

$$K = \frac{R_2'}{AK} \quad (1)$$

The conversion rules between parameters are shown in Table 1 below:

Table 1: Parameters of two types of epicycloids

Parameter name	Main parameter code	
	Variable-amplitude circumscribed epicycloid	Variable-amplitude inscribed epicycloid
Radius of the base circle	r1	r'1
Rolling radius	r2	r'2
Center distance between rolling circle and base circle	A	a
Swing rod length	a	A

Through the previous analysis, it can be calculated that the conversion relationship between the same two epicycloid base circle radii is

$$r_1' = k_1 r_1 \quad (2)$$

The short-amplitude epicycloid takes the center of the base circle as the origin, takes the center distance and the short-amplitude coefficient of two kinds of epicycloids as known parameters, and takes the rounding angle as a variable[5]. The parameter formula[14]has the following relationship:

In the following discussion, we will refer to the rounding angle 2α and call it the phase angle.

(1) establish a rectangular coordinate equation

The following equation holds:

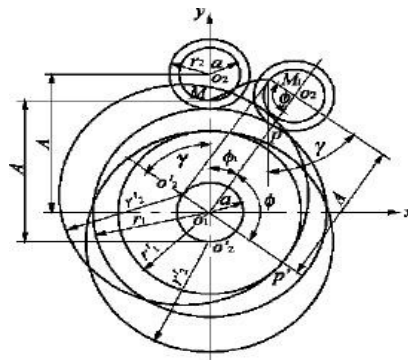

Figure 2: Short amplitude epicycloid principle

It can be seen that when K_1 is in Zone 1, the common polar coordinate parameter formula[15]of the luffing epicycloid becomes the polar coordinate formula of the standard epicycloid, and the change of the index A and A' is exactly the same as the above principle[6].

1.3. Tooth Profile Curve and Tooth Profile Equation of Cycloidal Gear

According to the above discussion, the geometric center of the cycloid gear is taken as the origin, and the axis coinciding with the symmetry axis of the tooth space of the cycloid gear is taken as the y-axis according to the origin, as shown in Figure 3, then it can be known that the radius of the central circle of the pin gear is R_p , all

And that radiu of the outer circle of the pin gear sleeve is R_{rp}

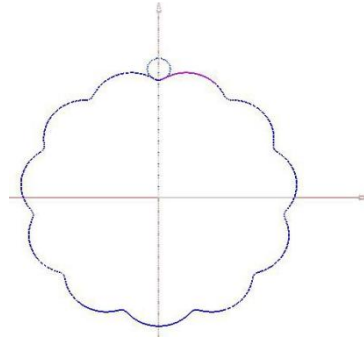

Figure 3: Diagram of parametric equation of cycloidal gear

The following equation relationship can be obtained Radius of curvature of cycloidal gear tooth profile

$$r = \frac{(x^2 + y^2)^{3/2}}{xy'' - y'y''} \quad (3)$$

In the equation:

r is the radius of the curvature of the luffing epicycloid

X is the first derivative of x , that $\frac{dx}{dt}$ is, X

Y is the first derivative with respect $\frac{dy}{dt}$ to, y

X is the second derivative of x with respect to $x = \frac{d^2x}{dt^2}$

Y is the second derivative of y with respect to $y = \frac{d^2y}{dt^2}$

The X and Y in equations (2-6) and (2-7) are derived from the first and second derivatives with respect to, respectively, to the equation with respect to:

$$r = \frac{A(1+K^2 - 2K \cos f)^{3/2}}{K(1+KA/a) \cos f - (1+K^3A/a)} \quad (4)$$

Substituting $K=1$ into equation (2-16), it is easy to obtain that the standard epicycloid radius of curvature is $r = \frac{4A \cdot a}{(A+a)} \sin^2(f/2)$

$$\text{Either } A = R_1 + R_2 \text{ or } A = R_2' \quad (5)$$

$$\text{Either } a = R_2 \text{ or } a = R_2' - R_1' \quad (6)$$

The radius of curvature of the actual cycloidal gear tooth profile curve I

$$r_1 = p + r = \frac{A(1+K^2 - 2K \cos f)^{3/2}}{K(1+KA/a) \cos f - (1+K^3A/a)} \quad (7)$$

For the convex theoretical tooth profile ($r < 0$), if $R_1 > p$, the equidistant curve of the theoretical tooth at this position will not be realized[7]. This phenomenon is called the "top cut" phenomenon of the cycloidal tooth profile. If the top cut is very serious, it will destroy the stability of continuous meshing, which is unacceptable[8]. If R_1 is equal to p , then $r = 0$, which means that the cycloid wheel has a sharp angle at this position, which is also unacceptable. If it is greater than zero, no matter what R_1 is, there is no need to worry about this situation[9].

Whether the cycloidal gear can appear the phenomenon of top cutting is not only related to the minimum radius of curvature of the theoretical convex tooth profile, but also determined

The radius of the tooth form of the needle tooth[10]. The tooth profile of the cycloidal gear does not have the top cutting phenomenon or the sharp angle phenomenon.

2. Force Analysis of Cycloidal Pin Gear Drive

The cycloid gear has three main forces: the acting force F_i when the pin gear is engaged with the cycloid gear, the acting force Q_i of the pin of the output mechanism on the cycloid gear, and the acting force F_{ro} of the arm bearing on the cycloidal gear [11].

2.1. The Acting Force When the Pin Gear Meshes with the Cycloid Gear

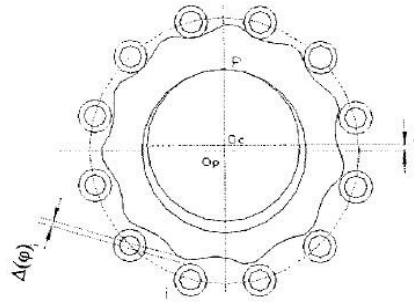

Figure 4: Initial engagement backlash caused by modification

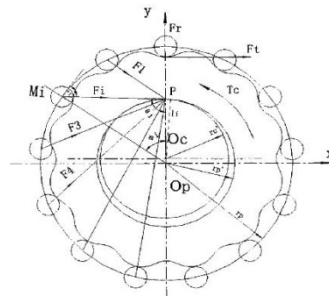

Figure 5: Gear tooth meshing force

(1) The same as the principle of gear transmission engagement, there is generally a backlash engagement to ensure reliable lubrication

$$D(f)1=Dr = \frac{\sin f}{\sqrt{1+K1^2-2K1\cos f1}} - \frac{Drp(1-K1\cos f)-\sqrt{1-K^2} \sin f}{\sqrt{1+k^2-2K\cos f}} \quad (8)$$

In the equation, θ_i is the rotation angle of the i th pin tooth about the rotating arm $o_p o_c$, and $K1$ is the short amplitude coefficient.

If θ_i is 0, $\cos \theta_i = K1$ is obtained according to the above calculation, that is, $\theta_i = \arccos K1$. This conclusion is the angle when the original backlash is zero. If it is unloaded, When a pair of $\theta_i = \arccos K1$ positions are engaged.

(2) The Basic Principle of Determining the Numerical Value of the Simultaneous Meshing Tooth of the Cycloidal Gear and the Pinwheel

If the load is transmitted, the moment applied to the cycloidal gear is T_c , under the action of T_c , due to the contact deformation w of the cycloidal gear and the pin gear and the bending deformation f of the pin gear pin, the cycloid gear rotates through an angle, and if the deformation of the cycloid gear body, the pin gear housing on which the pin tooth pin is installed and the rotating arm has little influence, it can be ignored [12-13]. Then the total deformation $W + f$ in the direction of the common normal of each meshing point of the cycloidal gear or the displacement in the direction of the normal of the point to be meshed is

$$d1 = \sum_{i=1}^{z/2} \dots \quad (9)$$

3. The Fourth Chapter is the Solid Modeling of Cycloid Pin Gear Reducer

3.1. UG Computer-Aided Design

A computer-aided design scheme is a modeling technique that focuses on information content and integrates multiple information systems. In the natural environment of computers, the design scheme, product analysis and modification depend on the ability of 3D modeling and organizational analysis of products[15]. Design improvement, adaptive simulation, FEM and PDM database management[16]. Therefore, the physical model of the virtual sample can be used to replace the physical sample in the whole product design process, and the development bottleneck of the manufacturing and testing of the physical sample in the new product development can be reasonably processed, so that the development progress is greatly shortened, and the product development cost is reduced[17]. Cost. Therefore, the 3D modeling of cycloidal reducer is an essential stage. The purpose is to intuitively reflect the cycloid reducer itself in the design scheme, predict and analyze its characteristics and make effective improvements, so 3D modeling and simulation are used to clarify the construction plan of the cycloid reducer. The plan is very necessary[18-19].

3.2. 3D Drawing of Parts of Cycloidal Pinwheel Reducer

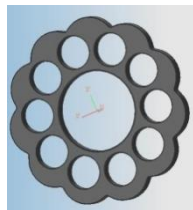

Figure 6: Cycloidal gear tooth profile

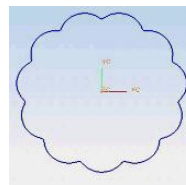

Figure 7: Cycloidal gear

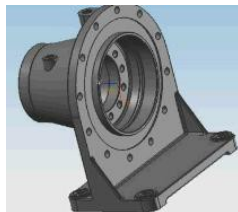

Figure 8: Box

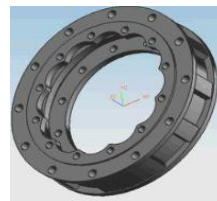

Figure 9: Pin Gear Housing

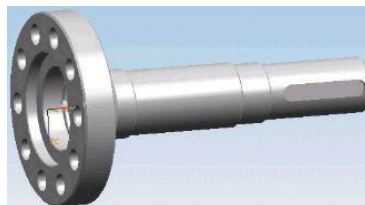

Figure 10: Output shaft



Figure 11: Exploded View for Assembly of Main Parts

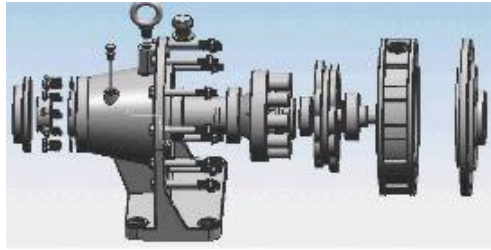

Figure 12: Exploded view of assembly drawing

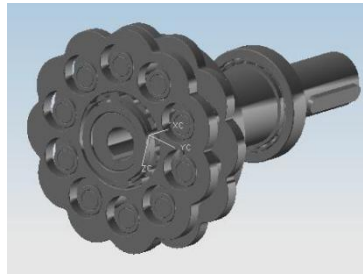

Figure 13: Cycloidal gear and output

Conclusion: After completing the scientific research on the subject matter of the present invention, the following conclusions can be drawn from the intensive study and the calculation of the design plan:

The large planetary transmission system of cycloidal needle reducer and the involute gear transmission system without tooth difference are the same as KHV gear. The principle and structure of the transmission system are basically the same[20]. The difference is that the tooth profile curve of the gear transmission of the large planetary transmission system of the cycloidal pinwheel reducer is not an involute gear, but a fixed distance curve of an ultra-abnormal external rotation line. Manage the cylindrical pin tooth at the conjugate point where the tooth profile of the central transmission is a curve[21].

Cycloidal pinwheel reducer is a new type of transmission system, which is based on the basic principle and design scheme of small planetary transmission system with small tooth difference according to the provisions of LF/T 29.83-98.

It is compared to a planetary drive system with smaller pitch and involute gears. Because it also has more than half of the teeth, it has greater load-bearing capacity and longer service life[22]. It has greater adaptability to the problems of fine tooth top collision and tooth profile coincidence intervention[24]. It has attracted more and more attention in the world and has been widely used in metallurgical industry, mining, chemical plants, ships, light industry, food, textile, lifting and transportation, military and other units. Its main disadvantages are complex processing technology and high production cost[25].

In the design of the reducer of cycloidal pinwheel reducer, a mathematical analysis model is established to increase the load capacity of the rotating wire wheel, and the optimal meshing angle is obtained by computer. Select the main parameters of the maintenance model; in the design of the pin gear housing ? Two supporting point type pins are selected to control the bending deformation of the pin teeth. In the layout of the equipment, the arrangement of the two cycloid wheels balances the stress of a shaft, reduces the stress of a bearing in a W mechanism, and improves the service life of the bearing.

4. Conclusions

One focus of this design program is to develop a design program for the reducer using an aided

design program, including a mathematical model file and conversion to a diagram. A difficult problem is the conversion of the tooth profile of the rotary wire drive. On the level of solving this problem, the relational calculation function of the model calculator of the rotary wire drive is converted into the profile of the rotary gear drive teeth. Selecting the aided design scheme can improve the unscientific structure in the design scheme, detect the assembly linearity and disassembly of the mechanical route design of the cycloidal pinwheel reducer, and analyze the assembly line efficiently, which can reduce scientific research and application. Reduce the cost, improve the quality of the assembly line, and make the economy of the design meet the requirements.

References

- [1] Edited by Qin Datong and Xie Liyang. *Handbook of Modern Mechanical Design (3)*[M]. Beijing Chemical Industry Press, 2002.
- [2] Hua Zhongping, Zhang Li. *Research on Algorithm of Optimal Cutting Stock of Angle Steel Based on Linear Programming* [C]. Annual Meeting of Mechanical Engineering Societies of Thirteen Provinces, Regions and Municipalities . 2005.
- [3] Yoon Do-jun. *Research on Wheel Reducer of Heavy Truck* [D]. Hefei University of Technology, 2010.
- [4] Ran Hengkui. *Design and Research of Wheel Reducer for Micro Electric Vehicle* [D]. 2008.
- [5] Du Xiuju, Qu Jifang, An Zijun. *Type Transformation of Pin-Ring Planetary Reducer* [J]. *Mechanics* , 2002, 029(001):58-59,62.
- [6] Xia Zhengquan, *New Cycloidal Pinwheel Reducer* [J]. *Practical machinery* ,10(2004) .
- [7] Zhang Zhan *Current situation and development trend of gear reducer* [J] *Huadian Technology*, 2001, 23 (001): 58-59
- [8] Sun Heng, Chen Zuomo, chief editor. *Mechanical principle* [M]. Beijing Higher Education Press, 2001.
- [9] L.Pust. *Weak and strong nonlinearities in magnetic bearings* [J]. *Mechanism and Machine Theory*, 39 (2004) 779-795.
- [10] Kuehnlw MR, Peeken H, Troeder C et al. *The Toroidal Drive. Mechanical Engineering*, 1981, 103 (2):32-39.
- [11] Chief Editor Zou Huijun. *Course Design Manual of Mechanical Principles* [M]. Beijing Higher Education Press, 1998.
- [12] Zhang Qian, *Analysis of Load Capacity of Lifting Cycloidal Pinwheel Reducer. Mechanical Design No 27, No.2, February 2010.*
- [13] Yu Ming, Seo Seung-yeon. *Based on Optimal Design of Cycloidal Pinwheel Drive Based on MATLAB. Modern Manufacturing Engineering Issue 8, 2010.*
- [14] *Compilation group of Baosteel Reducer Atlas. Baosteel reducer atlas* [M]. Beijing China Machine Press, 1995.
- [15] Rao Zhengang, *Design of Planetary Transmission Mechanism* [M] Version 2. Beijing National Defense Industry Press. 1994.
- [16] Lee Young-min. *Talk about the principle of cycloidal pinwheel reducer Use and maintenance* [J]. *Yunnan building materials* , 1992(2):36-39.
- [17] Liu Huiying, Yang Zhiqiang. *Comprehensive Course Design of Mechanical Foundation* [M]. Beijing China Machine Press, 2002.
- [18] Pu Lianggui, Ji Minggang. *Mechanical design* [M]. Beijing Higher Education Press, 1996.
- [19] Liu Hongwen, chief editor. *Mechanics of materials* [M]. Beijing Higher Education Press, 1992.9
- [20] Duan Hongjie, Tao Hao, *Numerical Design of Cycloidal Gear of Cycloidal Pinwheel Planetary Reducer, Coal Mining Machinery, December 2009.*
- [21] Guan Tianmin, Zhang Dongsheng. *Research and Optimization Design of the Converse Bow Tooth Profile in Cycloid Gear Planetary Transmission* [J]. *Journal of Mechanical Engineering* , 2005, 041(001):151-156.
- [22] Cheng Daxian. *Handbook of Mechanical Design* [K]. Beijing Chemical Industry Press. 1993.
- [23] Jiang Genghua et al. *Mechanical Transmission Design Manual* [K]. Beijing Coal Industry Press, 1982.
- [24] Luo Wen, Xiang Zhanqin. *Based on Finite element analysis of cycloidal pinwheel reducer based on COSMOS works. Mechanical and electrical engineering* , May 2010.
- [25] Hou Yi, Song Dynasty Province. *Visual Design of Cycloid Pin Gear Planetary Reducer* [J]. *CAD/CAM and Manufacturing Informatization*, 2006 (6): 52-53.