

# *Intelligent Prosthetic Knee and Ankle Coordination Control System Based on Virtual Reality*

**Gongxing Yan\***

*College of architectural engineering, Luzhou Vocational and Technical College, Luzhou 646000, Sichuan, China*

*yaaangx@126.com*

*\*Corresponding author*

**Keywords:** Intelligent Prosthesis, Virtual Reality, Gait Recognition, Knee Ankle Coordination Controller

**Abstract:** With the development of science and technology, intelligent prosthesis has gradually become the focus of research in the prosthesis industry. Its main feature is that it can automatically adjust the parameters of stride and pace according to the changes of external environment. However, it can't change with the change of step frequency and knee joint angle. Based on the above background, the purpose of this study is to research and design the knee ankle coordination control system of intelligent prosthesis based on virtual reality. In this study, the modular design method is used to build virtual scene and supporting equipment. Then, by analyzing the gait characteristics of normal people, the structure of knee joint and ankle joint of prosthesis and the working principle of control cylinder are introduced, and the control strategy under asynchronous speed is established. At the same time, the manual control debugging system and the upper computer debugging mode are combined to verify the human walking gait in the way of clinical simulation and realize the coordinated control of the knee and ankle. The results showed that the healthy limbs of amputees were 63.698% in fast speed, 66.104% in medium speed and 66.104% in slow speed, which were slightly longer than those of normal people; the prostheses were 60.114% in fast speed, 61.237% in medium speed and 61.676% in slow speed, which were not significantly different from those of normal people.

## **1. Introduction**

As a result of various accidents, thousands of people with lower extremity disability have been caused in the society. According to relevant data, about 110000 people in the United States lose their lower limbs every year. At present, the number of disabled people in China is as high as 6 million. Because these amputees have lost the most basic walking ability of human beings, they are difficult

to take good care of themselves in life, and they are objectively placed in a specific corner away from the mainstream of society, which makes them full of physical and mental pain not in the human body. In order to restore the normal walking function of these people, people invented a substitute, which can realize the lower limbs. For the first time, people used sticks instead of walking without legs. With the development of society and the progress of science and technology, in the first half of last century, the developed countries, represented by the United States, have carried out large-scale research on the technology of artificial legs, and the research and development of artificial legs have made great progress in theory and practice. The products of this period are traditional artificial legs made of wood, leather, aluminum and steel. It was not until the second half of the last century that prosthetic technology developed rapidly. But before the 1980s, products could only perform simple standing and walking functions.

Due to the importance of intelligent prosthesis research, many research teams began to study intelligent prosthesis, and achieved good results. For example, Galvao has studied a method to provide artificial vision for users with vision impairment who have implanted visual prosthesis. The method includes configuring an intelligent prosthesis to perform at least one of a plurality of functions in response to selection information received from a user to facilitate the execution of visual tasks. The method also includes extracting item information related to at least one item related to a visual task in the scene from an input image signal generated in response to an optical input representing the scene. Then, the intelligent prosthesis generates image data corresponding to the abstract representation of the scene, which includes the representation of at least one item. Then, pixel information based on image data is provided to the visual prosthesis [1-2]. Fu is committed to the development of Mechatronics platform for tactile research of intelligent prostheses. The platform is designed to stimulate a tactile sensor array with multiple indenters driven by an automatic positioner to provide repeatable stimulation with a controllable force. The special requirements of making the platform suitable for the sensitive plane of fingertip bending of intelligent artificial hand are put forward. Fu introduced the design of Mechatronics platform and its performance in the simulation process [3-4]. Although the current research results are relatively rich, there are still deficiencies, mainly reflected in the high R & D funding.

In the research of coordinated control system, virtual reality technology is a good method, which can solve many research and development problems, so it is widely used in the research of coordinated control system. For example, Zhu outlined the development of a virtual reality system for aircraft inspection and training. Virtual reality has generated a lot of excitement, but there is little formal evidence that it is useful. However, because the virtual reality interface is difficult to build and expensive, the computer graphics community needs to be able to predict which applications will benefit from virtual reality. In order to solve this important problem, Zhu studies and measures the immersion and presence of the subjects in the virtual environment simulator. Specifically, in the Virtual Reality Laboratory of Clemson University, it conducted two comparative studies using the virtual reality system developed for a visual inspection task of the aft cargo hold. In addition to assembling visual inspection virtual environment, an important goal of the project is to explore the subjective existence that affects task performance. The results of Zhu study show that the system scores very high on the issues related to the subjects' perceived existence [5-6]. Due to the effectiveness of virtual reality technology, can virtual reality technology be applied to the research of

what intelligent prosthesis knee ankle coordination control system to solve the problem of insufficient research and development funds.

Based on the analysis of the characteristics of human lower limb movement, a method of knee ankle joint coordination based on terminal machine is established in this paper. By only placing Hall sensor on the knee joint, we can predict the basic information of ankle joint, coordinate the movement of ankle joint, and control the walking of prosthesis.

## **2. Knee Ankle Coordination Control System of Prosthesis**

### **2.1. Virtual Reality Technology**

Virtual reality technology is a highly integrated technology, such as real-time three-dimensional image generation technology, sensor technology, recognition and positioning technology, visual tracking technology, three-dimensional display technology, multi perception technology, voice input and output technology. Through the combination of various technologies, simulate the user's perception of the real environment and enhance the sense of immersion [7].

(1) Immersion. Virtual reality technology uses computers to generate realistic three-dimensional environment entity images. After users wear helmets and other devices, combined with the presentation of three-dimensional entity products in virtual environment, it is like watching, touching and evaluating exhibits in a real exhibition hall.

(2) Interactivity. The human-computer interaction design in the virtual reality system simulates the natural interaction behavior of human in the real environment. The user can use the handle, position tracker, data glove and other sensing devices to interact with the virtual object, and simulate the picking up and dropping of the product in the virtual environment, and the product changes direction with the rotation of the hand [8].

(3) Multiple senses. Because virtual reality system contains many sensing devices, including vision, hearing, touch, taste and other sensing devices, users can see the complete product modeling features in the virtual environment, hear the sound of the product touching the desktop when it is placed, and sense the existence and movement of the product [9].

### **2.2. Lower Limb Movement**

(1) Walking on the flat ground in daily life is one of the most basic and regular movements of the lower half of the body and feet, and also one of the characteristics of the difference between people and animals [10-11]. In the process of walking, the movement state of healthy people refers to moving forward with their feet to make their bodies reach the level of movement. In the normal step cycle, it can be divided into two stages: support period and swing period. The supporting period includes one leg supporting period and two legs supporting period [12]. The supporting period refers to the period when the lower limbs contact the ground and gradually bear the weight. It refers to the stage when the heel of the same foot touches the ground from the ground to the fingers, accounting for about 60% of the whole walking cycle. Its function is to cushion and help the knee to fully expand. Bipolar support phase is the most stable phase in the cycle [13]. When patients encounter walking obstacles,

the first solution they often think of is to extend the time of two-way support, slow down the walking speed and increase the stability of walking. There is an empirical relationship between the time and frequency of foot support, as shown in formula (1):

$$t_{ds} = (-0.16f + 29.08)t_p / 100 \quad (1)$$

Among them,  $t_{ds}$  represents the support time of the feet,  $f$  represents the walking frequency, and  $t_p$  represents the gait cycle. The swing cycle refers to the period in which the lower limbs rotate forward in the air, and refers to the mud on the heel of the finger on the same side, accounting for about 40% of the entire walking cycle.

According to the analysis of human movement characteristics, the control requirements for the knee joint when walking on the ground are: Do not play soft foot support when carrying weight, that is to ensure that the prosthetic product will not swing back and forth after entering the support period, which is the most basic requirement for prosthetic products. In order to ensure stability and safety, the rolling control on the walking horizontal plane requires the swing close to the healthy side, and the speed can be adjusted in real time [14-15].

## (2) Up/down stairs

Under normal circumstances, people with disabilities cannot wear prosthetics on the stairs like normal people. They must first reach the health edge, wait for the health edge to drop to the previous step, and then force the artificial edge upward, and slowly descend to the health edge [16]. On the steps on the same floor, the added knee joint will not bend during the whole process and will always stretch [17]. In addition, some active prosthetics can alternately move the legs like a healthy person, but now, this increase should provide positive strength and can bear weight when the prosthetic knee is bent, without hitting the soft feet.

Similarly, there are two methods for patients with thigh amputation to go downstairs: 1) Generally, the addition can only be performed one step at a time. The healthy end drops first, and after the fixed end stands firm, the prosthetic end quickly follows. He could not bear the weight when bending down, so the prosthetic knee joint was in tension [18-19]. 2) As a healthy person, walk down the stairs step by step. At this time, the addition must have a bending action to ensure stability and safety.

## 2.3. Selection of Human Gait Features

The characteristic pedestrian parameters especially include pedestrian circulation, pedestrian phase and connection angle [20]. On the side of the heel, on the same side of the heel, it is counted as a walking circle. The traditional walking cycle begins with the heel on the ground [21]. In fact, this is not limited to this. You can use any point in the walking cycle as the starting point of the walking cycle [22-23]. Ground torque should be used as the starting point for tread separation. In a circle, we can divide it into a support period and a swing period, and the angle of the knee joint will change during walking [24].

The joint angles of the lower limbs are defined as follows (as shown in Figure 1), where  $\theta_h$ ,  $\theta_k$ ,

and  $\theta_a$  are the angle values in motion of the hip, knee, and ankle joints. Flexion and extension: The joint moves along the coronal axis, so that the two bones are close to each other, the angle is reduced to flexion, and the angle is increased to extension. Hip angle: the angle between the longitudinal axis of the trunk and the longitudinal axis of the femur, the flexion is "positive" and the extension is "negative". Knee angle: the angle between the extension line of the longitudinal axis of the femur and the parallel line of the longitudinal axis of the tibia [25]. Ankle angle: the angle between the fifth metatarsal and the lateral midline of the fibula minus  $90^\circ$ . Dorsal flexion is "positive" ( $0-20^\circ$ ) and plantar flexion is "negative" ( $0-45^\circ$ ).

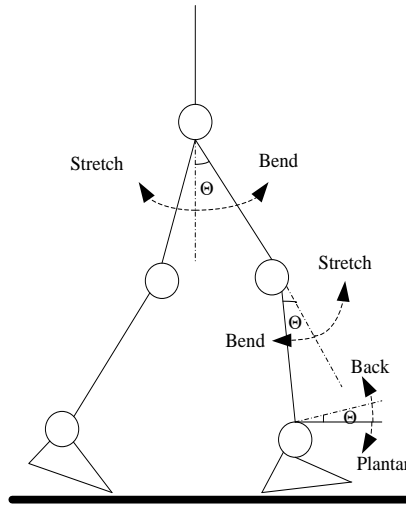

Figure 1: Angles of joints of lower limbs

## 2.4. Finite State Machine Control Method

A finite state machine (FSM) is a mathematical model that represents finite states and the transitions and effects between these states. It includes a set of statements, a set of input events, a set of output events and a state transition function. Each situation represents an aspect of system behavior, and the full range of system behavior is a collection of all possible system conditions. The output engine should decide whether to change the output state based on the system input and the current state of the system.

The specific finite state machine can be expressed as six series, as shown in formula (2).

$$M = (I, O, S, S_o, \delta, \lambda) \quad (2)$$

Among them,  $S$  is the state symbol set, which contains all the states in the model, such as formula (3).

$$S = (S_0, S_1, \dots, S_{n-1}) \quad (3)$$

$I$  is the input symbol set, which defines the input of all states in the model, such as formula (4).

$$I = (I_1, I_2, \dots, I_m) \quad (4)$$

$O$  is the output symbol set, which defines the output of all states in the model, such as formula (5).

$$O = (O_1, O_2, \dots, O_p) \quad (5)$$

$S_0$  is the initial state,  $\delta : S \times I \rightarrow S$  is the state transition function, and  $\lambda : S \times I \rightarrow O$  is the output function.

An extended finite state machine  $M$  is a quintuple, as shown in formula (6).

$$M = (I, O, S, x, T) \quad (6)$$

Among them,  $I$  is the input symbol set,  $O$  is the output symbol set,  $S$  is the state set,  $x$  is the environment variable, and  $T$  is the conversion set, such as formula (7).

$$T = (s, q, i, o, pt, at) \quad (7)$$

Among them,  $s, q$  is the start and end state of the conversion,  $i, o$  is the input and output of the conversion  $T$ .  $pt$  is the conversion predicate, which is related to the current environment variable. Only when the condition becomes immediate  $pt = TRUE$  can the  $at$  conversion be triggered. When the environment is triggered, the environment variable changes.

The finite state machine is usually represented by a state transition diagram. As shown in Figure 2, certain conditions must be met before the situation changes.

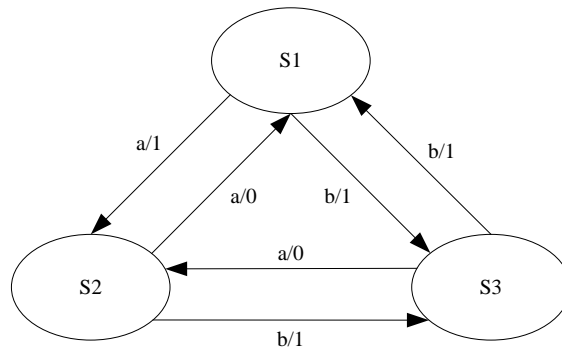

Figure 2: State transition diagram

FSM can be expressed using a state transition diagram. In addition, you can also use different types of state transition tables (as shown in Table 1). Table 1 is the most common representation: the combination of the current state (B) and the condition (Y) indicates the next state (C).

Table 1: State transition table

Current status →	State A	State B	State C

Condition ↓			
Condition X	...	...	...
Condition Y	...	State C	...
Condition Z	...	...	...

In practical applications, depending on whether the finite state machine uses input signals, it is divided into two types: Moore type finite state machine and Milley type finite state machine. That is, the exit of Moore's finite state can be regarded as a function of the current situation, 2) Mealy type finite state machine: its output signal is not only related to the current playback state, but also related to all input signals; At the end of life, the machine outputs it is considered as a function of the current state and all input signals. The principle of the finite state machine is shown in Figure 3.

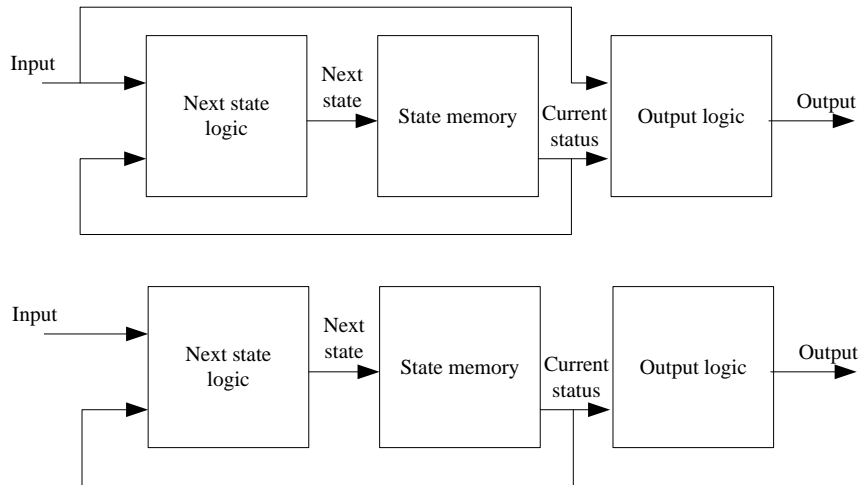

Figure 3: The principle of finite state machine

The advantages of this study are simple operation and good visualization effect. However, there are some restrictions on using the finite state machine test method, namely: 1) the behavior of the model is restricted, (2) the conditions for institutional change are limited; 3) the system is always kept in specific circumstances; 4) the system is in specific circumstances. It has a unique response behavior; 5) The time required for migration is almost zero.

### 3. Control System Design

#### 3.1. Experimental Control System Hardware Design

The intelligent knee and ankle coordination controller is powered by a lithium battery. Therefore, the selection of the main controller and other devices must strictly comply with the requirements of low power consumption, because its mechanical structure has been designed; in addition, the area of the circuit board should also be strictly limited. Try to save space. According to the functional requirements of the system, the material design of the controller specifically includes: single-chip

feedback unit, power supply unit, sensor unit, stepper motor unit, serial communication unit, ultrasonic communication unit, etc. The design of the control circuit should meet the following requirements: (1) Choose a main control chip that can provide a rich area and multiple interfaces: meet the operational requirements of data acquisition, control, and communication. (2) There is a power management module specially designed to meet the voltage requirements of different parts of the system. (3) System requirements with relatively strong computing power and real-time processing of large amounts of data. The hardware block diagram of the system is shown in Figure 4.

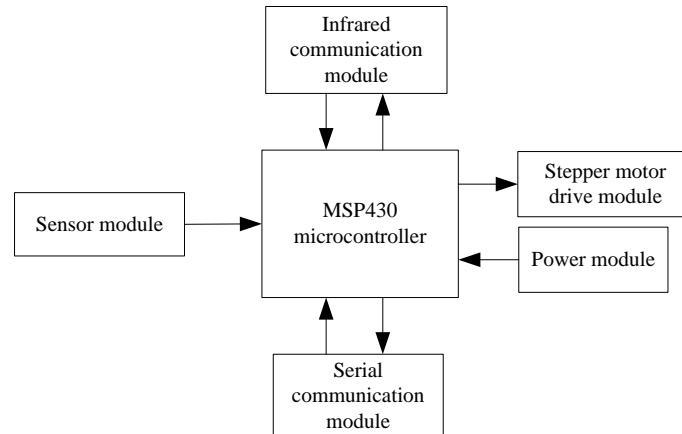

Figure 4: Block diagram of the hardware

### 3.2. Experimental Database Design

The intelligent gene and ankle joint coordination error detection software designed in this research is a visual application development tool written in Microsoft basic class library (MFC) of Visual C + +. The English full name of MFC is Microsoft basic class, which is Microsoft's main class library. It contains many defined items and an implementation framework. Program developers can develop on the basis of the framework, which greatly reduces the workload of developers. The main program function includes the initialization work after power on, such as circuit initialization, clock configuration, etc. after initialization, the controller will enter the low energy consumption state and wait for the next interrupt. If an interrupt occurs, the interrupt program is executed. After the end of the terminal level, continue to return to the low consumption state before the terminal. The flow chart of the main program is shown in Figure 5.



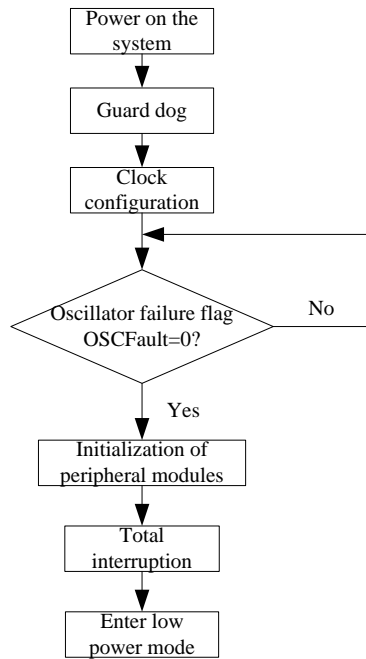

Figure 5: Program flow chart

After the system is powered on, first close the watchdog to avoid CPU reset, then configure the clock, set the DCO to 1MHz, and the end VI frequency at the moment is 1MHz, which can meet the clock frequency requirements of the control algorithm. P1, P2 and P4 are peripheral module ports, watchdog timer WDT and communication module usarto. Adjust P1 and P4 ports to output mode, provide stepping engine control pulse and P2 port to close mode. Timer 1 allows the terminal to be in up counting mode, clock source is smclk, timer 2 allows the terminal to control the motor. Usarto is in UART mode, with baud rate of 9600bps, and can receive and receive interrupt. Smclk clock source is selected to realize communication between upper computer and infrared remote control. Adcl0 analog-to-digital conversion module has 8 external input channels, A6 channel is selected, single channel single conversion, pulse sampling mode is adopted, the clock source is smclk, and the time is 3.3 microseconds, which can be used to test the battery power. After the initialization of the module, the total interrupt is turned on. After the main program is finished, the system enters the low energy consumption state and waits for the interrupt signal.

### 3.3. Establishment of Experimental Virtual Scene

Under the virtual reality environment, the knee and ankle of the intelligent prosthesis will switch the real intelligent prosthesis to the virtual intelligent prosthesis. With the virtual reality headwear display device as the medium, the corresponding target content and user interaction behavior will also change.

Through the establishment of virtual reality scene, the virtual reality scene is presented to the trainees, and then the user action information is obtained through the system hardware, and the user operation matching the real action is synchronously displayed in the virtual scene. Finally, the user operation effect is displayed in the virtual scene in real time. Through the display of this series of

virtual reality scenes and the feedback and output of user's man-machine operation information, the equipment technology trial can achieve twice the result with half the effort.

After the establishment of virtual scene, the function of data acquisition and communication system can not be ignored. Its function is to collect the trainees' operation data in real time, convert them into electrical signals in real time, drive the virtual software to realize corresponding actions, and feed back the operation status to the operation device. Because there are many kinds of detection equipment used in the mine, it is necessary to prepare their own communication protocols according to different equipment, and stipulate the type and value range of variable input and output.

#### 4. Simulation Analysis of Intelligent Prosthetic Coordinated Control System in Virtual Reality

##### 4.1. Analysis of Coordinated Control System

The pressure sensor model selected in this study is FSR 402. The pressure information can be obtained by converting the pressure exerted by the membrane area of FSR sensor into the change of resistance value. The higher the pressure, the lower the resistance. A pressure sensor is arranged at the foot bottom to detect the contact with the ground. When the pressure sensor contacts the ground, the output of the sensor outputs a specific voltage value. The curve of pressure and output voltage is shown in Figure 6. The resistance value of RM selected in the system is 30K. When the pressure sensor leaves the ground, the output voltage is 0V. When the pressure sensor begins to contact the ground, the output voltage is 4.1V, the voltage output of the sensor is connected with the signal regulating circuit, and the level of I / O port suitable for the microcontroller will be sent to the microcontroller.

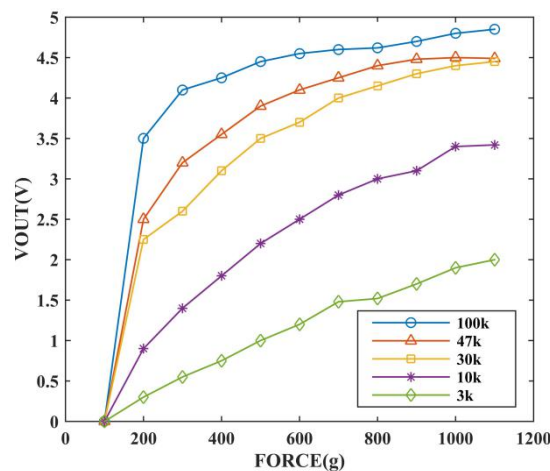

Figure 6: Pressure vs. output voltage curve

The pressure sensor must be installed on the sole of the foot when in use. This installation is very simple and is not suitable for installation on thrusters. However, the installation of the pressure sensor is simple, and the support period and the swing period can be more carefully divided, so it is recommended to conduct data acquisition experiments in the laboratory.

The human knee has only one degree of freedom, so a single-degree-of-freedom linear mechanical system driven by a DC motor is constructed. The drive can be seen as  $K_C$ . The transmission

$$\frac{K_g}{s}$$

mechanism is represented as  $s$ . The execution motor uses a DC servo motor, and the transfer function can be expressed as a secondary link. Due to the small inductance of the motor circuit, under

$$\frac{1/C_e}{T_m S + 1}$$

certain conditions, it is basically a primary inertial link. In the case of a specific angular position of the  $\theta(t)$  knee joint,  $y(t)$  is the angular position of the actuator output. The control accuracy is calculated as follows:

$$e = \sqrt{\frac{\sum_{i=1}^n (y_{di} - y_i)^2}{n}} \quad (8)$$

Take  $|e| < 0.01$  as the evaluation index.

On the basis of speed recognition developed in this project, coordinated movement of wearing knees and ankles, in order to carry out asynchronous fast walking on the ground, virtual reality activities were carried out among volunteers whose knees were severed. The changes in the angles of the joints of the lower extremities under different conditions are recorded as shown in Figure 7. The angle changes of the knees, waists, and ankles of the patients who were disconnected when walking slowly.

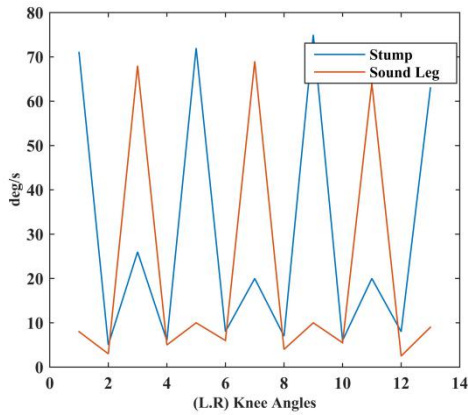

(a) Knee joint

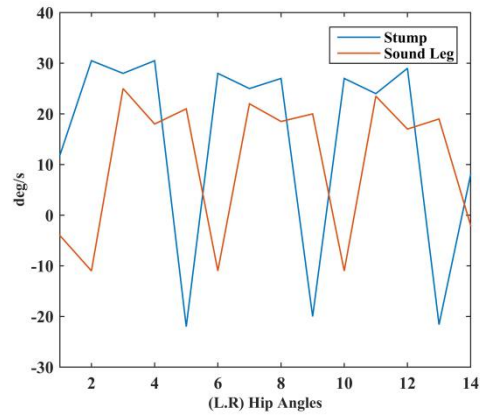

(b) Hip joint

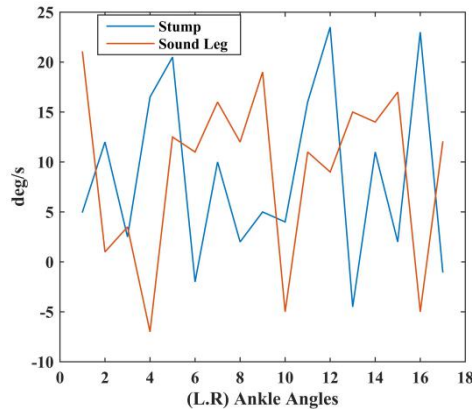

(c) Ankle joint

Figure 7: Knee, hip, and ankle angle curves

During the swing, the angle symmetry of the knee joints on both sides of the residual limb and the healthy limb is very good, which achieves the control purpose. During muscle cross-linking, even though it is known that the amputated knee of the amputated patient will not flex, he is physically afraid of sudden flexion. Therefore, the maximum angle of muscle crossing on the side of the residual limb is much smaller than the angle on the side of the healthy lower limb. Because the disconnected patient has a short time to try the thruster, he is not used to the new thruster and cannot overcome the psychological fear of knee bending or falling. After getting used to it for a while, this phenomenon will be greatly improved. The ankle joint is mainly used to assist the movement of the knee joint in human walking. Therefore, the angle curve of the ankle joint is the same as the angle curve of the ankle joint of the healthy limb, which is basically consistent with the purpose of adjusting the knee and the ankle.

Volunteers whose knees have been severed are fitted with coordinated artificial joints for knees and ankles based on finite state machines. First of all, according to the daily walking habits of prosthetics, it can be divided into slow, medium and fast walking. Then, the pace will change randomly while walking. In the above experiment, each stage must be fully repeated, and the trajectory of each stage is recorded at 3 speeds, and the time of each stage is compared. As shown in Table 2.

Table 2: Comparison of gait cycles at three paces

	Optimal fast		Optimum speed		Best slow	
	Fitness	Prosthesis	Fitness	Prosthesis	Fitness	Prosthesis
Support time/s	0.709	0.668	0.859	0.797	0.952	0.888
The proportion(%)	63.698	60.114	66.104	61.237	65.361	61.676
Swing period time/s	0.411	0.456	0.452	0.511	0.499	0.549

The proportion(%)	36.291	40.012	33.857	38.783	34.592	38.333
-------------------	--------	--------	--------	--------	--------	--------

It can be seen from the table that the support period of the healthy person is slightly longer than that of the normal person, and the support period of the healthy person accounts for about 60 to 62% of the entire walking cycle. The healthy limbs of the severed patients were 63.6698% at high speed, 66.104% at medium speed, and 66.104% at low speed, which was slightly longer than ordinary people. Prosthetic limbs have a high speed of 60.114%, a medium speed of 61.237%, and a low speed of 61.676%. Similar to ordinary people.

#### 4.2. Analysis of Knee-ankle Coordinated Prosthetic Walking

If a disabled person finds that the coordinated patch of the knee and ankle of this study is installed at the opening of the joint valve of the asynchronous knee and ankle, a coordinated walking experiment of the knee and ankle can be performed. The system debugging experiment is shown in Figure 8.

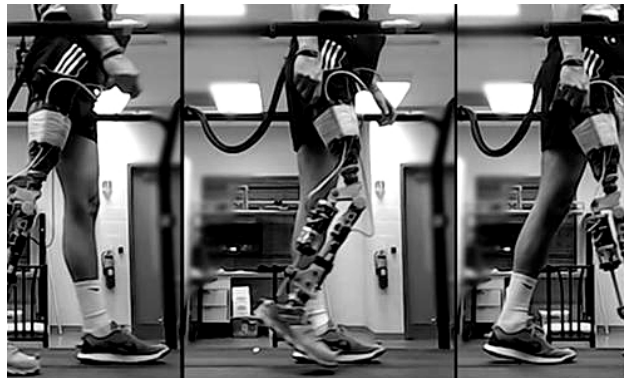

Figure 8: Experimental diagram of system debugging

VICON three-dimensional motion capture system is used to collect, process, export and perform statistical analysis of walking experiment data. In order to analyze the differences in walking between the healthy limbs and the side of the stumps when walking with disabilities and wearing knees and ankles for supplementary adjustment, a detailed study was conducted. Comparison of the angle of the knee joint between the patch side and the patch side of the knee and ankle coordinated supplement user, and the comparison of the knee joint angle between the patch side and the patch side of the knee and ankle coordinated supplement user. As shown in Figure 9.

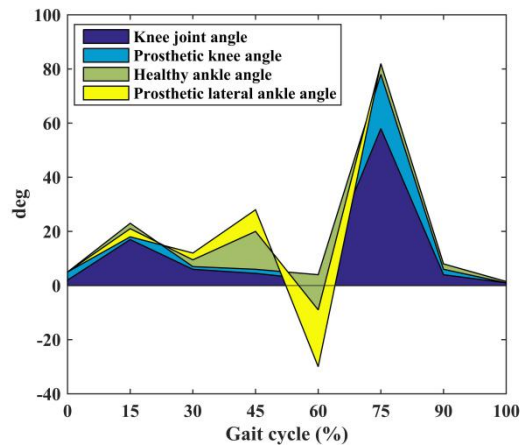

Figure 9: Knee-ankle coordinated prosthetic wearer compared with the healthy limb side and the prosthetic side

Judging from the test results, the intelligently coordinated knee and ankle joints based on scrapped machine testing methods add display: specific accuracy. When the amputee wears a cleverly coordinated knee and ankle while walking, the angle curve of the knee and ankle shows good symmetry with the healthy side of the extremities. For the knee joint, the angle of the added knee joint is basically the same as the normal person, but because the addition is caused by the joint action of the residual limb and the soil, if the prosthetic knee joint is bent too much, it will affect the impact of the residual limb on the residual limb. Due to the mechanical structure of the artificial knee joint itself, the degree of change in the angle of the knee joint on the residual limb side is significantly lower than that on the healthy limb side. For the ankle joint, the actual angular width of the artificial ankle joint ranges from 10 degrees of spine tilt to 15 degrees of pelvic tilt, which can basically mimic the walking characteristics of ankle joints of normal people. After the finger of the normal person leaves the ground, the tilt of the pelvis continues to increase, but after the artificial ankle joint enters the swing period, because there is no energy and no external power, after the swing cycle begins, the pelvic contraction will decrease and eventually return to the initial balance. Generally speaking, this kind of intelligent and coordinated knee and ankle joint addition can basically simulate the gait of a normal person and monitor healthy limbs to achieve the purpose of coordinated movement of the knee and ankle joints.

## 5. Conclusions

Intelligent prosthesis is a high-tech product that integrates information collection and processing, pattern recognition, electronics, control, machinery, robotics and human mechanics technology. It is a new trend in the development of the prosthesis industry. This research is based on the research and design of a virtual reality-based intelligent prosthetic knee and ankle coordinated control system. The virtual reality system mainly completes the design and construction of the virtual environment through three-dimensional modeling, database support, and virtual scene presentation, and realizes the learning of the theory and operation methods of detection equipment through human-computer interaction. Through the establishment of virtual reality environment and the discovery of the use

process of disabled people, the use and learning methods of this technology can greatly improve the quality and efficiency of technology, not only can attract disabled people to learn actively, but also easy to master the relevant knowledge in use.

In this study, we carefully analyze the walking characteristics of ordinary people when walking, select various suitable sensors to collect walking information during walking, analyze the corresponding obstacles when the disabled adjust their knees and ankles to supplement walking, and focus on the analysis of the angle signal changes of knee joints. In the leg, the relationship between the foot time of the neck joint, the time of the toes leaving the ground and the angle of the artificial knee joint, and the relationship between the angle of the artificial knee joint and the position of the cylinder piston were analyzed. By installing a Hall sensor, you can predict the walking information of the prosthetic leg and knee joint.

This study also used a 3D Weikang motion capture system to collect various sports information from prosthetic users. Real-time comparison shows that the knee-ankle joint coordination intelligent system developed by this research can realize the monitoring of knee-ankle joint angle to meet the basic walking requirements of patients with lower limb amputation and formulate relevant technical standards.

## Acknowledgements

This work was supported by Chongqing Technology Innovation and application development project (cstc2019jscx-msxmx0278) and Chongqing natural fund project (cstc2018jcyj 0805).

## References

- [1] Galvao J R , Zamarreno C R , Martelli C , et al. *Smart Carbon Fiber Transtibial Prosthesis Based on Embedded Fiber Bragg Gratings*[J]. *IEEE Sensors Journal*, 2018, 18(4):1520-1527.
- [2] Chang M , Kim K , Jeon D . *Research on Terrain Identification of the Smart Prosthetic Ankle by Fuzzy Logic*[J]. *IEEE Transactions on Neural Systems & Rehabilitation Engineering*, 2019, 27(9):1801-1809.
- [3] Fu, Qiang, Wang, DaiHua, Xu, Lei. *A magnetorheological damper-based prosthetic knee (MRPK) and sliding mode tracking control method for an MRPK-based lower limb prosthesis*[J]. *Smart Material Structures*, 2017, 26(4):045030.
- [4] Zhidkov A V , Pashmentova A S , Viun S S , et al. *The Mathematical Simulation and Study of the Electrical Resistance of the Friction Zone of the Hip Joint Endoprosthesis with a Metal–Metal Friction Pair*[J]. *Journal of Friction & Wear*, 2018, 39(3):251-258.
- [5] Zhu W , Fan G . *Application of computer virtual reality technology in virtual tour*[J]. *International Journal of Advanced Media & Communication*, 2016, 6(2):273-282.
- [6] Maples-Keller J L , Bunnell B E , Kim S J , et al. *The Use of Virtual Reality Technology in the Treatment of Anxiety and Other Psychiatric Disorders*[J]. *Harvard Review of Psychiatry*, 2017, 25(3):103-113.



- [7] Chen H . *Research of Virtools Virtual Reality Technology to Landscape Designing*[J]. *Open Construction & Building Technology Journal*, 2015, 9(1):164-169.
- [8] Hongjun Chen. *Retraction Notice: Research of Virtools Virtual Reality Technology to Landscape Designing*[J]. *Open Construction & Building Technology Journal*, 2016, 10(1):186-186.
- [9] Z. Liang, R. Shuang. *Research on the value identification and protection of traditional village based on virtual reality technology*[J]. *boletin tecnico/technical bulletin*, 2017, 55(4):592-600.
- [10] Salil A , Michiel P , Heike V . *Influence of body weight unloading on human gait characteristics: a systematic review*[J]. *Journal of Neuroengineering & Rehabilitation*, 2018, 15(1):53-.
- [11] Li P F , Li M J , Chen X , et al. *Research on long range characteristics of human gait cycle based on electrostatic signals*[J]. *Tien Tzu Hsueh Pao/Acta Electronica Sinica*, 2015, 43(6):1078-1083.
- [12] Deng M , Wang C , Chen Q . *Human gait recognition based on deterministic learning through multiple views fusion*[J]. *Pattern recognition letters*, 2016, 78(Jul.15):56-63.
- [13] Anusha R , Jaidhar C D . *Clothing invariant human gait recognition using modified local optimal oriented pattern binary descriptor*[J]. *Multimedia Tools and Applications*, 2020, 79(3):2873-2896.
- [14] Roberts D , Quacinella J , Kim J H . *Energy expenditure of a biped walking robot: instantaneous and degree-of-freedom-based instrumentation with human gait implications*[J]. *Robotica*, 2017, 35(5):1054-1071.
- [15] Shpakov A V , Voronov A V . *Studies of the Effects of Simulated Weightlessness and Lunar Gravitation on the Biomechanical Parameters of Gait in Humans*[J]. *Neuroence and Behavioral Physiology*, 2018, 48(9):1-8.
- [16] YONEDA, Masahiro. *A study on quantitative evaluation method for hemiplegic gait from the viewpoint of application to medical rehabilitation*[J]. *Transactions of the Jsme*, 2016, 82(839):16-00008-16-00008.
- [17] Kyung-Ryoul M , Gyuwon S , Sungkuk C , et al. *Gait Estimation from Anatomical Foot Parameters Measured by a Foot Feature Measurement System using a Deep Neural Network Model*[J]. *Scientific Reports*, 2018, 8(1):9879-.
- [18] Solopova I A , Selionov V A , Zhvansky D S , et al. *Human cervical spinal cord circuitry activated by tonic input can generate rhythmic arm movements*[J]. *Journal of Neurophysiology*, 2015, 115(2):jn.00897.2015.
- [19] Zaier R , Al-Yahmedi A . *Design of Biomechanical Legs with a Passive Toe Joint for Enhanced Human-like Walking*[J]. *Journal of Engineering Research*, 2017, 14(2):166.
- [20] Kim K H , Kim S G , Hwangbo G . *The effects of horse-riding simulator exercise and Kendall exercise on the forward head posture*[J]. *Journal of Physical Therapy Science*, 2015, 27(4):1125-1127.



- [21] Shourijeh M S , Mcphee J . *Foot–ground contact modeling within human gait simulations: from Kelvin–Voigt to hyper-volumetric models*[J]. *Multibody System Dynamics*, 2015, 35(4):393-407.
- [22] Kwon J W , Son S M , Lee N K . *Changes in upper-extremity muscle activities due to head position in subjects with a forward head posture and rounded shoulders*[J]. *Journal of Physical Therapy Science*, 2015, 27(6):1739-1742.
- [23] Zare F E , Maghooli K . *Human Verification Using a Combination of Static and Dynamic Characteristics in Foot Pressure Images*[J]. *Journal of Medical Signals & Sensors*, 2016, 6(4):224-230.
- [24] Scaglioni-Solano P , Aragón-Vargas, Luis Fernando. *Gait characteristics and sensory abilities of older adults are modulated by gender*[J]. *Gait & Posture*, 2015, 42(1):54-59.
- [25] Gardner A W , Montgomery P S , Casanegra A I , et al. *Association between gait characteristics and endothelial oxidative stress and inflammation in patients with symptomatic peripheral artery disease*[J]. *Age*, 2016, 38(3):64.