

# *Power Budget Analysis of a Distributed 5G EPON Network*

Syed R.Zaidi<sup>1,a</sup>

<sup>1</sup>*Bronx Community College of the City University of New York, 2155 University Av., Bronx NY, USA*  
*a. syed.zaidi@bcc.cuny.edu*

**Keywords:** PON, Power Budget, 5G and Distributed Architecture.

**Abstract:** This work studies the power-budget analysis of a fully distributed ring-based EPON (Ethernet Passive Optical Network) architecture that enables the support of a converged PON-5G access networking transport infrastructure that is capable to seamlessly backhaul both mobile and wireline multimedia traffic and services.

## 1. Introduction

To date, mainstream Ethernet Passive Optical Network (EPON) bandwidth allocation schemes as well as the new IEEE 802.3ah Ethernet in the First Mile (EFM) Task Force specifications have been centralized, relying on a component in the central office (Optical Line Termination (OLT)) to provision upstream traffic [1-3]. Hence, the OLT is the only device that can arbitrate time-division access to the shared channel. Since the OLT has global knowledge of the state of the entire network, this is a centralized control plane in which the OLT has centralized intelligence. One of the major problems associated with a centralized architecture is the “single-point of failure” problem that is the failure of the OLT software will bring down the whole access network. Another major problem is that the PON architecture is typically centralized but 5G RAN architecture is intrinsically distributed. Thus the PON architecture must support a distributed architecture as well as distributed radio network control and management (NCM) operations.

In this paper we utilize proposed distributed solutions to this problem such as found in [4] that proves that these distributed networking architectures solutions and the associated bandwidth allocation algorithms and protocols have characteristics that make them far better suited for provisioning Quality of Service (QoS) schemes necessary for properly handling data, voice, video, and other real-time streaming advanced multimedia services over a single line. This paper introduces standalone ring architecture in normal and protected states and then presents the power budget analysis

## 2. Standalone Ring-Based EPON Architecture

### 2.1. Normal State

The standalone architecture refers here to just the wire line segment of the hybrid architecture without incorporating the wireless segment the small cells. Fig. 1 illustrates the standalone ring-based EPON architecture. An OLT is connected to N ONUs via a 20 km trunk feeder fiber, a passive 3-port optical circulator, and a short distribution fiber ring. To cover the same local access area as in the typical tree-based architecture, the small ring at the end of the trunk is assumed to have a 1-2 km diameter.

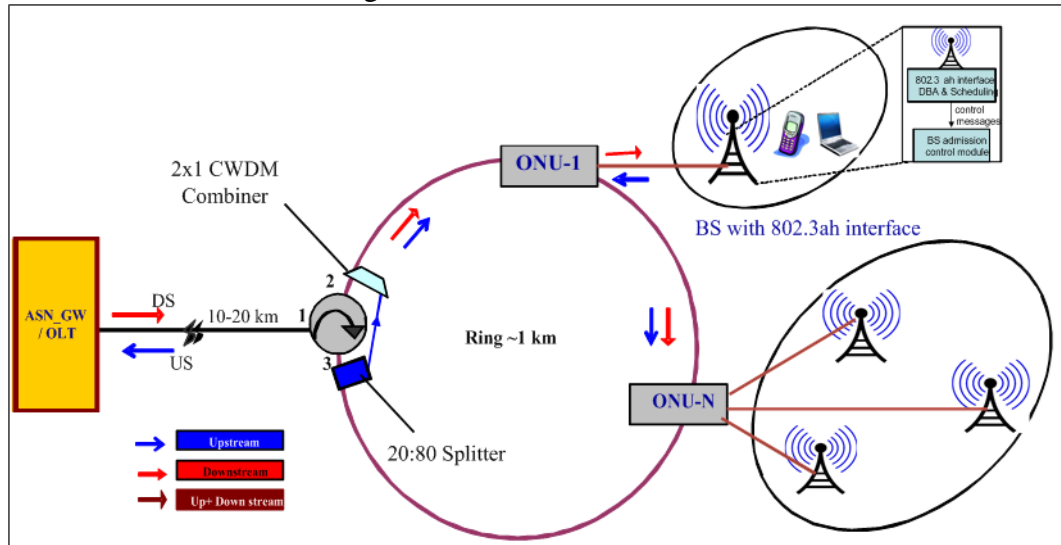

Figure 1: Standalone Ring Architecture

The ONUs are joined by point-to-point links in a closed loop around the access ring. The links are unidirectional: both downstream (DS) and upstream (US) signals (combined signal) are transmitted in one direction only. The US signal is transmitted sequentially, bit by bit, around the ring from one node to the next where it is terminated, processed, regenerated, and retransmitted at each node (ONU). Since US transmission is based on a TDMA scheme, inter-ONU traffic (LAN data and control messages) is transmitted along with upstream traffic destined to the OLT (MAN/WAN data) within the same preassigned time slot. Thus, in addition to the conventional transceiver maintained at each ONU (a  $\lambda_{up}$  US transmitter (Tx) and a  $\lambda_{d}$  DS receiver), this approach requires an extra receiver (Rx) tuned at  $\lambda_{up}$  to process the received US/LAN signal.

DS signal is coupled to the ring at port 2 of the optical circulator. After recombining it with the recirculated US signal via the 2x1 CWDM combiner placed on the ring directly after the optical circulator, the combined signal then circulates around the ring (ONU1 through ONUN) in a Drop-and-Go fashion, where the DS signal is finally terminated at the last ONU. The US signal emerging from the last ONU is split into two replicas via the 20:80 1x2 passive splitter (Fig. 1) placed on the ring directly after the last ONU. The first replica (80 %) is directed towards the OLT via circulator ports 1 and 3, where it is then received and processed by the US Rx (housed at the OLT), which accepts only MAN/WAN traffic, discards LAN traffic, and process the control messages, while the second replica (20 %) is allowed to recirculate around the ring after recombining with the DS signal via the 2x1 CWDM combiner.

## 2.2. Protected State

The protected architecture as shown in fig. 2 is identical to that of the normal working architecture except for the following additional components: i) a redundant trunk fiber and distribution fiber ring; ii) a redundant transceiver pair located at the OLT; iii), Automatic Protection Switching (APS) module located at each ONU. The APS module attached to each ONU monitors the state of its adjacent distribution fiber paths and the state of the ONU and performs both fault detection and the APS functions. Each APS module houses a commercially available low loss 4x4 bidirectional Optical Switch (OS) that is capable of switching from any port to any port used for switching between working and protection fibers. It also includes two detection circuits comprised of a 1x2 CWDM filter (to separate the combined DS/US signal), a control circuit to configure the OS, and a p-i-n detector (except the first ONU (ONU1), which has two p-i-n detectors at the first detection circuit). The first

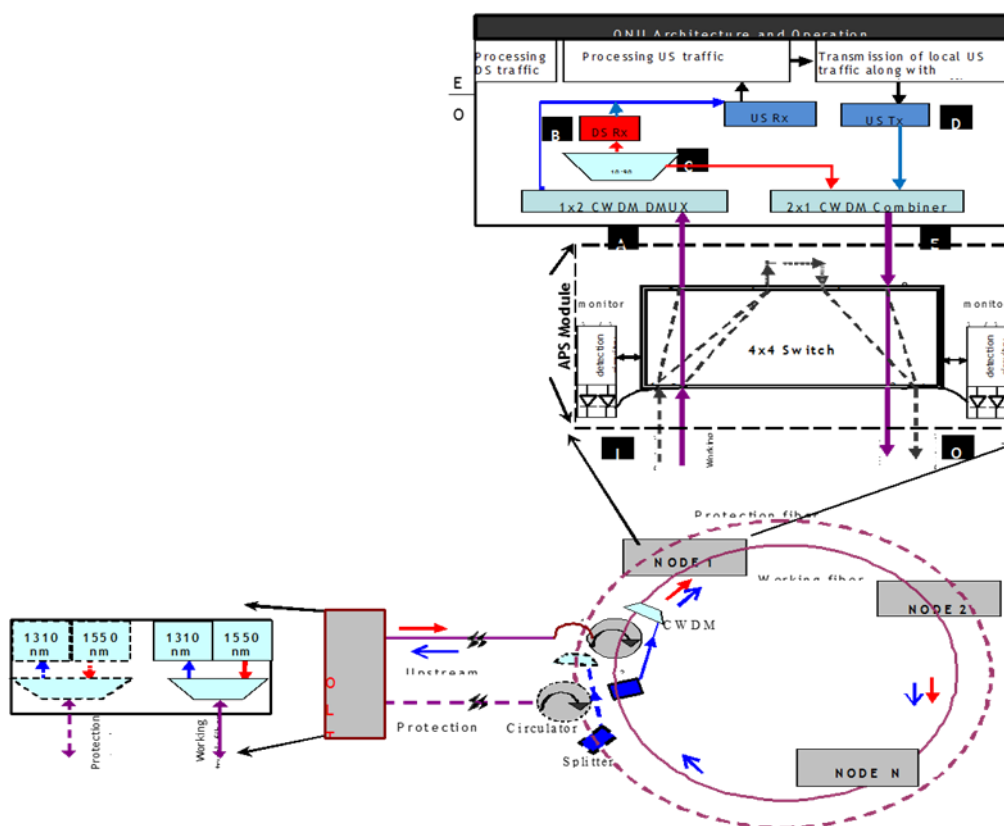

Figure 2: Protected State

detection circuit of each ONU (except the first ONU) is used to detect only the US signal via tapping a small portion (about 1%) of the incoming combined (DS/US) signal and passing it through the CWDM filter. On the other hand, the first detection circuit of the first ONU is used to detect both US and DS signals. Likewise, the second detection circuit of each ONU is used to detect the outgoing US signal via tapping a small portion (about 1%) of the outgoing combined signal.

## 2.3. Recovery Time

Recovery time is defined here as the time elapsed from when a failure occurs to when service is fully restored and a new cycle resumes. The total recovery time is the sum of several delay components including timeout, fault detection time, REPORT/GATE transmission time/propagation

delays/processing times, and OS switching time. In general, the switching time is much longer than all other delay components combined and, therefore, the total recovery time is mainly dominated by the switching time (about 13 ms) [5]

## 2.4. Power Budget and Scalability Analysis

The scalability of the proposed working state architecture is mainly limited by the concatenated splitter losses encountered by the DS signal at each node. Since the US signal is regenerated at every node, typical limited US power budget problems as well as the utilization of the 10 Gbps US burst-mode Tx/Rx and associated design challenges at the ONU/OLT are totally eliminated. To examine the performance impact of the DS power budget under the assumption of a fixed (10:90) tap ratio at each ONU, we consider the worst-case scenario by calculating the total ODN loss (passive optical elements (e.g., splitters, combiners, fibers, connectors, switches and splices forming an optical path), incurred by the DS signal on its optical path from the OLT to the second to last ONU ( $ONU_{N-1}$ ). There are two types of losses encountered by the DS signal at each node. The first type is Drop-component,  $IL_{Drop}$ ) and the second type is (Express-component,  $IL_{Express}$ ). Table 1 quantifies both types of losses assuming typical commercially available CWDM components.

Table 1: Parameters used in the model

Type of Loss	Path IAB (Drop)	Path IAEO (Express)
Splitter-10/90 (A)	10.0	0.45
CWDM	0.5	2x0.45
Access Ring Fiber Loss	0.0	0.125
Switch (I-A)/(E-O)	0.5	2x0.5
<b>Total IL (dB)</b>		
Working	10.5	1.60
Protected	11.0	2.60

The total ODN loss incurred by the downstream signal on its path to  $ONU_{N-1}$  is:

$$IL_{Total\_Loss}^{ONU_{N-1}} = IL_{trunk}^{fiber} + 2IL_{CWDM} + (N - 2)IL_{Express}^{ONU} + IL_{Drop}^{ONU} + IL_{Ring}^{fiber} \quad (1)$$

Assuming a 20 km trunk feeder fiber (0.25 dB/km loss), the first ONU is 20 km away from the OLT, and the last ONU is 23.2 km away from the OLT (ring circumference is about 3.2 km; 1 km diameter), and the IEEE 802.3av 10G-EPON highest power budget class (PR/PRX30) parameters [6] with a DS Rx (APD w/FEC) sensitivity of  $-28.5$  dBm and OLT Tx optical power of  $+2$  dBm, the total number of ONUs that can be adequately supported is equal to 10 ONUs, (see Fig. 3).

As for the protected state architecture, the signals encounter the additional OS and tap loss at each node. Assuming a 0.5 dB insertion loss per OS, the total number of ONUs that can be adequately supported by the protected architecture is reduced to 7 ONUs shown in Fig. 4.

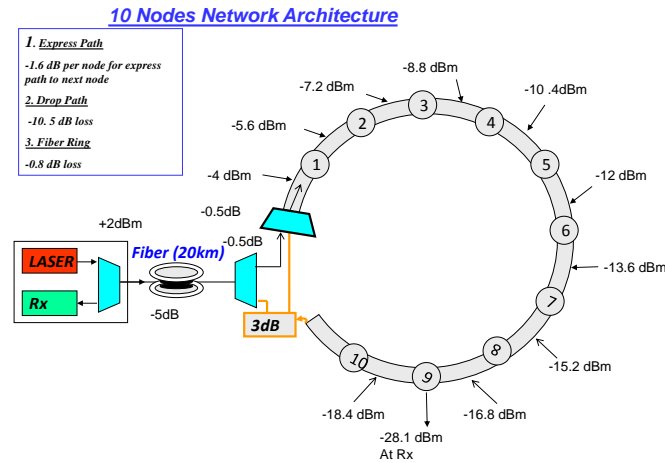

Figure 3: 10 Node Architecture

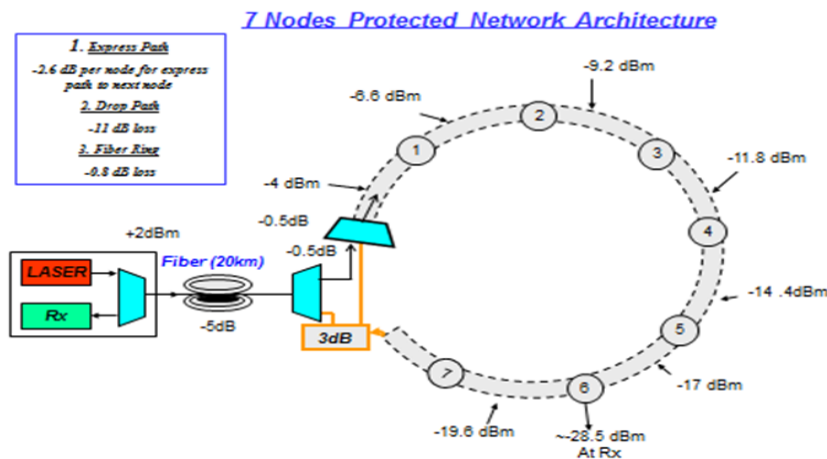

Figure 4: 7 Node Protected State Architecture

### 3. Conclusions

This paper introduces power budget analysis of distributed Ring-EPON-5G network architecture in normal and protected states. With a DS Rx (APD w/FEC) sensitivity of  $-28.5$  dBm and OLT Tx optical power of  $+2$  dBm, the total number of ONUs that can be adequately supported is equal to 10 ONUs in the normal state. For the protected state architecture, the signals encounter the additional OS and tap loss at each node. Assuming a  $0.5$  dB insertion loss per OS, the total number of ONUs that can be adequately supported by the protected architecture is reduced to 7 ONUs. For the future work, we will research to see how many ONUs can be supported while increasing the input signal level of OLT.

### References

[1] G. Kramer, et al. "Ethernet PON: Design and Analysis of an Optical Access Network," *Photonic Network Communications Journal*, vol. 3, No. 3, July 2001.

- [2] Sherif R, Antonis Hadjiantonis, George Ellinas "A novel Decentralized Ethernet based PON Access Architecture for provisioning Differentiated QoS," *Journal of Light Wave Technology*, Vol.22, No.11, November 2004
- [3] Chang-Hee Lee, Wayne V. Soriano, Byoung Yoon Kim "Fiber to the Home Using a PON Infrastructure," *Journal of Light Wave Technology*, Vol.24, No.12, December 2006.
- [4] S. R. Zaidi, "An efficient & Cost-Effective EPON-Based Next Generation 5G Mobile Backhaul RAN Architecture," 2021 23rd International Conference on Advanced Communication Technology (ICACT), PyeongChang, Korea (South), pp. 248-253, 2021.
- [5] <http://www.dbmoptics.com/products/gpoti/switches.php>
- [6] K. Tanaka, A. Agata, Y. Horiuchi, "IEEE 802.3av 10G-EPON standardization and its research and development status", *IEEE/OSA Journal of Light. Techn*, 28(4):651-661, Feb. 2010