

Research on Application of Four Rotor Aircraft in Cruise Navigation

Zitong Lin^a, Xuan Zhang^b, Wenkang Guo^c, Zongyu Li^d and Zhiyuan Xu^{e,*}

School of Navigation and Naval Architecture, Dalian Ocean University, Dalian 116000, China

^alzt950214@163.com, ^b1772205344@qq.com, ^czhuan1232141@163.com, ^d158701115@qq.com, ^exuzhiyuan@dlou.edu.cn

*Corresponding author: xuzhiyuan@dlou.edu.cn

Keywords: four rotorcraft, cruise, navigation

Abstract: [Objective] in order to solve many problems such as high risk, high cost, high consumption and low efficiency in artificial time, this paper proposes a method of using artificial unmanned aerial vehicles instead of fishermen to go to sea artificially. [Method] the characteristics of six degrees of freedom of four rotorcraft can be used to achieve better cruising purposes. [Results] the aircraft can navigate freely on the water surface and feedback the sea state information in real time. [Conclusion] this application can avoid the high risk of Artificial Sea Patrol, greatly reduce the high cost and high efficiency of the artificial sea patrol, and improve the efficiency of the Sea Patrol.

1. Introduction

It is understood that whether it is a seafood cultivation or marine fishing fishermen, in order to ensure the production benefits, there will be a daily work of patrol the sea, usually using the Artificial Sea Patrol mode, not only time-consuming and laborious, but also facing the complex situation of cold and hot weather, the high cost of fuel consumption, and so on. It is impossible to use the radar and other measuring instruments to accurately measure obstacles. This requires seaman to observe the safety of the front area on the surface wave and the color of the water surface. This observation method is difficult to avoid the influence of geographical environment such as distance, color, light and visibility, for ship drivers who don't often cross the reef line, they often make mistakes in judgment. The consequence is that the ship will run aground on the rocks, and the hull will break and cause serious accidents, which will cause potential safety hazards in navigation. However, our original intention is to change the way of patrolling the sea, using UAVs, omni directional and full time sea patrol and navigation. It is based on its advantages of simple manufacture, low cost, simple operation, and low difficulty of palm grip, small safety risk coefficient, low ground support requirements, and wide survey angle. Instead of the original artificial sea patrol, it can not only help drivers navigate safely in reef areas, but also help drivers make reasonable decisions and save a lot of manpower, material resources and financial resources.

2. Hidden dangers and problems of artificial Cruise

In many countries, there have been tragic accidents caused by touching reefs, but the damage is the hull, but the heavy casualties are countless lives. It can be said that natural disasters and human disasters are all the same. However, some of these accidents are due to blind driving, some of which are negligence, but the reason is that hidden reefs have not been discovered or found too late, so there is a hidden danger in the artificial sea patrol. When we patrol the sea, we need to use our own boat or boat to explore the route we are going to see. Whether there will be a dark island reef or other sea bottom obstacles will threaten the voyage. When [1] Sailors observe, they will be most likely to be reflected by the sea, the distance of view and the influence of the waves, So as to judge the irreparable consequences caused by mistakes. The second is to increase the cost of ship fuel and consume more cost. Such artificial cruise not only requires very high observation ability of sailors, but also requires a lot of energy to ensure the safe sailing of ships, which is time-consuming and laborious. If we can develop a kind of offshore UAVs that can detect reef conditions, it will play an important role in maritime safety.

3. Solution to manual Sea Patrol

The mini navigation nautical aircraft uses a small four rotor aircraft design, so that it can make its aircraft more stable. In case of strong winds, it can also ensure smooth flight. UAV also improves the wind resistance rating, the 6 channel setup of the four rotorcraft, and the increase of the number of functions. The [2] UAV shell has made waterproof and hydrophobic handling devices. At the bottom of the aircraft and the four sides of the flight motor, the polyurethane rigid foam plastic floating angle is installed. If the aircraft falls into the sea carelessly, it can float on its own to reboot and salvage. When a small-scale navigation exploration UAV is available, if the ship enters the reef filled area, it can start to release the small-scale navigation exploration UAV to replace the ship for navigation exploration. At the same time, the four systems of small-scale navigation UAV can be divided into four, namely, flight control system, remote control system, power system, record return system and information processing system. Flight control system is the central system of the command. How does flight control aircraft maintenance posture? This is because flight control includes "cerebellum". That is to say, there are multiple sensors to control the flight and attitude adjustment of the UAV. The remote control system includes the remote controller on the ground and the two modules on the receiving end of the aircraft. There are four channels of pitching, rolling, heading and throttle two rockers. These instructions are transmitted by wireless signals to the aircraft through the transmitter of the remote control. The signal is received by the receiving module on the aircraft. The power system consists of an electronic governor, which converts the direct current from the power battery to the three alternating current, which can directly drive the motor. After receiving the flight control commands, the motor speed is controlled, so that the inclination angle of the aircraft can be changed. The most important thing is to record and send back the system, which is to shoot or videotape the sea area around the ship at sea, and send it back to the control personnel or the driver's watch, to check and analyze whether there is a hidden reef that obstructs or threatens the safety of the ship. The intelligence analysis system with independent alarm will be studied, and the size of the sea bottom shadow and spray will be input to assist the duty driver or UAV controller to judge. This helps drivers to analyze more conveniently and carefully and to choose safe navigation routes, which reduces the pressure and labor intensity of drivers when they enter these areas. It can also help drivers make reasonable decisions.

4. Features and advantages of small navigational surveillance UAVs

4.1 Design features of small navigational surveillance UAV

The UAV is made up of four rotors in the structure, and is symmetrical in the four directions of the front and rear sides of the body. The four rotors are in the same height plane, four motors are installed on the bracket end of the aircraft symmetrically, and the flight control computer and the external equipment are installed in the middle of the bracket. The design sketch is as follows.

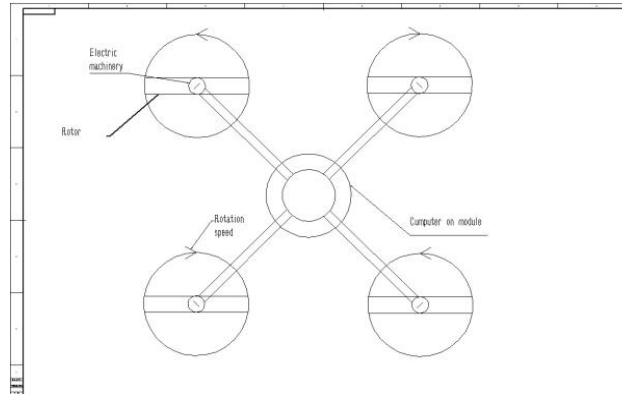

Figure. 1 Design sketch of t3.1-1 Mini navigation UAV

The small navigational situation drone changes the rotor speed by adjusting the speed of four motors to control the change of lift force, so as to control the attitude, movement and position of the aircraft. The mini navigation nautical aircraft is a six degree of freedom vertical lift with only four input forces, but there are six state outputs, that is, the system is under actuated system. The following are the six states of the UAV, [3]

(1) Up and down motion

By motor throttle control, throttle increase, four motor speed increases at the same time, lift increases, and then the aircraft moves upward.

(2) Front and rear movements

It is controlled by the pitch angle of the aircraft. If the aircraft is tilted forward, the lift will counteract the gravity in the vertical direction and provide the acceleration of the aircraft in horizontal direction.

(3) Right and left movement

It is controlled by the roll angle of an aircraft, with the principle of forward and backward motion.

(4) Pitching movement

Turning around the Y axis of the aircraft body coordinate system, the speed of motors 1 and 2 decreases while the aircraft is heading down, while the speed of the 3 and 4 motors increases, and the reverse torque of the four motors is still offset each other.

(5) Rolling motion

Revolve around the X axis of the aircraft body coordinate system, which is the same as pitching motion.

(6) Yaw motion

Turn around the Z axis of the aircraft body coordinate system. If the speed of the 1 and 3 motors increases, and the speed of the 2 and 4 motors decreases, the reverse torque of the motor cannot be offset each other. The counter torque will appear clockwise, and the aircraft will sail to the right.

In terms of motor drive, the small navigation nautical aircraft uses four axis special electrical adjustment, which transforms the control signal of the flight control board into the current size to regulate the motor speed, and adjusts the current to the current that the flight control board can withstand, and at the same time changes the voltage to power the flight control board and remote control.

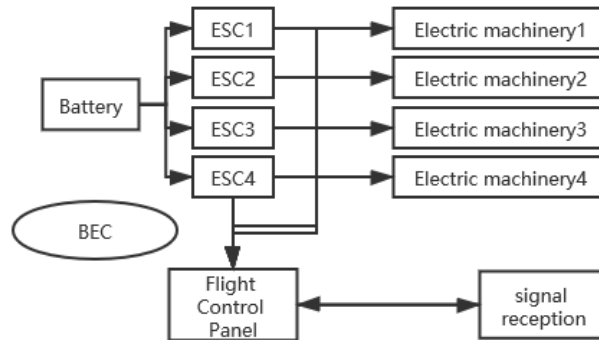

Figure. 2 Motor drive design sketch

Because of the four axis flight requirements, the electrical response is fast, while the electrical adjustment has the difference between fast response and slow response, so the four axis needs quick response.

4.2 Advantages of small navigational surveillance UAVs

Small navigational surveillance UAV has three advantages. First of all, it is practical. The crew surveyed the surrounding waters by UAVs, which expanded the potential danger range of the ship drivers, reduced the probability of erroneous judgement. And missed the alarm during the observation, and reduced the pressure of the driver's overlooking. For uncertain targets, it can be observed at close intervals of three hundred and sixty degrees without dead angle. Secondly, it is targeted. Small navigational UAVs are specially designed for navigation. Compared with ordinary UAVs in the world, small navigation nautical aircraft can achieve stronger wind and wave resistance, higher water tightness, and remove the entertainment function of UAVs in the market. The bottom of the bracket is also designed with the floating angle of polyurethane rigid foam, which is convenient for salvaging, landing and taking off again in the water. Finally, it is economic. Considering the strong protection of the UAVs in the sea, they will still fall into the sea for various reasons, damage, and fall or disappear. Our UAV will consider the use of smaller UAVs. The cost and the selling price are much lower, which makes up for the problem caused by the size reduction of UAV. [4]

5. The future market of UAVs

In modern times, the application of UAV is no longer a new problem. The UAV has been applied to many fields, such as street scene shooting, surveillance and patrol. This UAV with camera device is used to carry out large-scale aerial photography to achieve aerial overlooking effect. In the field of Power Patrol, UAVs equipped with high-definition digital cameras and cameras and GPS positioning system are used. It can be positioned along the grid, independently cruise, transmit images in real time, monitor and monitor synchronously on the computer. In addition, in the field of traffic surveillance, UAV participates in the traffic management of the city, and can play its own

expertise and advantages. To help public security urban traffic control departments to jointly solve the traffic jam situation in large and medium-sized cities. UAVs can not only ensure the implementation of the urban traffic development plan from the macro perspective, but also carry out real time monitoring and traffic flow regulation from the micro level, and To build a three-dimensional traffic management system of water, land and space, one space and three dimensional traffic management system, so as to realize regional control and ensure smooth traffic and deal with unexpected traffic incidents. Emergency rescue can also be carried out. However, few people in the world have ever heard of the use of professional equipment for exploring the reef by UAVs in navigation. This shows that the market is still a new field, and the call of the corresponding maritime powers, the local governments are also strongly supporting the development of the navigation market, so the potential market is unthinkable. [5].

6. Conclusion

In this paper, the application of small navigational exploration UAV in navigation field is demonstrated. It is proved that the small navigational exploration UAV is efficient, convenient, time-saving and safe instead of Artificial Sea Patrol. It can meet the requirements of Sea Patrol under severe wind and waves. As well as the development of unmanned aerial vehicles (UAV), they belong to the frontiers. Therefore, this article only discusses the application of the nautical aircraft in the field of navigation. At the same time, we can apply this technology to our coastal defense business. Compared with the real fighter cruise, our UAV will have great application prospects through improvement. Energy consumption will be greatly reduced. At the same time, it can also reduce the probability of casualties. In the future, small navigational UAV will keep pace with the times and constantly improve and develop.

Acknowledgments

This work was financially supported by Innovation and entrepreneurship training program for college students in Dalian Ocean University in 2019 fund (provincial level, 201910158007), Liaoning Provincial Education Department's 2019 Scientific Research Funding Project (QL201911).

References

- [1] Li Dongning, Zhu Huaiwei, Zheng Zhongyi. Cause analysis of ship grounding. *Traffic world (Jian Yang, machinery)*. 06 (2009).
- [2] Liu Yanwei, Liu Sanwa, Wang Li Meng, Niu Fuzhou, Li Peng Yang, Li Yan. Tilting deformation four rotor aircraft modeling and flight simulation [j/ol]. *Mechanical science and technology*, 2020, 1-6.
- [3] Lai Sheng Sheng, Chen Xindu, Wu Lei, Lv Sijie, Xu Xue. Optimal design of three degree of freedom underactuated robot system [j]. *Machine tool and hydraulic*, 03 (2020), 14-17.
- [4] Zhang Weidong, Liu Xiaocheng, Han Peng. Research progress and challenges of UAV system [j]. *Journal of automation*, 1-11.
- [5] Chen Xing Da. Overview of the application and development of offshore UAVs [j]. *China strategic emerging industries*, 12 (2018), 47.