

# *Assessment of damage on Reinforced Concrete Frame Structures under Seismic Aftershock in Kuwait*

**Bader A. Abdullah<sup>a,\*</sup>, Khaled Sh Alajmi<sup>b</sup>**

*Trainer, Construction Training Institute -The Public Authority for Applied Education & Training (PAAET)*

<sup>a.</sup> *ba.faraj@paaet.edu.kw*, <sup>b.</sup> *ks.alajmi@paaet.edu.kw*

*\*Corresponding author*

**Keywords:** Kuwait National Seismic Network (KNSN), Non-linear material, Elasto-Plastic behavior, Dynamic implicit, FEA and Earthquake.

**Abstract:** With the accelerated process of urbanization of Kuwait, urban high-rise buildings are getting more and higher and closer between each other. The risk due to the collapse of buildings under earthquake is more and more great. Due to the unpredictability of earthquake, as well as the discreteness of seismic waves, the preferred method used by engineers in the structural design is to enhance the ability for reducing earthquake damage. This paper employed data extracted from the Kuwait National Seismic Network (KNSN) in order to estimate the seismic response of an RCC structure in Kuwait. In the codes for seismic design of different countries, both the safety and the economy of the structure are taken into account. In addition to the elastic analysis under "small earthquake", the elastic-plastic analysis under "strong earthquake" is necessary. When the response of the structure under strong earthquake is beyond the scope of the elasticity, the structure behavior will be changed from elastic status to elastic-plastic status. FEA analysis has proved its importance in doing such non-linear implicit material analysis. This paper studied the behavior of a three store building subjected to Dynamic loads in Elastic-Plastic Region of the material using data available on Kuwait National Seismic Network (KNSN) websites.

## **Introduction**

Kuwait is prone to earthquakes due to different related plate motion alongside the Gulf of Aden as well as left-lateral motion in Red Sea Rift alongside the Dead Sea Fault and conjunction to the northeast and north as the plate is driven alongside Eurasia (ArRajehi et al., 2010). The Kuwait Institute for Seismic Research (KISR) and LLNL has a joint project in order to improve an

enhanced velocity model designed for the recently installed national network event location. This network of laboratories is helping in producing a robust system of earthquake monitoring and damage assessment (Rodgers et al., 2003).

## Literature Review

Samanta & Tripathi (2009) simulated the elastic response of the substitute frame in their paper. 3D modeling of frame was done in ABAQUS to achieve more realistic solution. In this paper, 3D linear hexahedral lower order liner element C3D8I that employs unsuited modes was utilized. For purpose of analysis, a model was prepared with consideration of (1) concrete to be like a solid homogeneous isotropic medium that utilizes linear elasticity depending on constitutive model and (2) solid element with lower order in order to characterize the concrete medium that decreases the required time. Further, a comparative study was done with standard analytical methods like and STAAD Pro analysis (matrix analysis method) and Moment distribution method.

Jankowiak and Lodygowski (2005) analyzed a three-dimensional concrete cube modeled through smeared crack model as well as concrete damaged plasticity method. The model validation for the preferred behavior in monotonic loading was discussed later. Using concrete damage as well as smeared crack plasticity method, it was noticed that concrete shows in the two cases a perfectly nonlinear behavior while in using smeared crack modeling in mesh size 25, the resulted stress-strain curve provides max stress around 29.39 MPa at 0.00190 strains where then once the curve demonstrates the descendent nature. In Chaudhari and Chakrabarti (2012) study, the method and requirement of the material parameters for identification of concrete damage plasticity were studied. For that purpose, laboratory tests were conducted. They have used two standard applications. The first is analysis of 3 points bending single notched concrete edge beam sample. The second presents the four points bending single notched concrete edge beam sample in static loading. The parameters which were identified are  $\beta$ ,  $\gamma$ ,  $m$  and  $f$ . The parameter  $\beta$  and  $m$  were used to describe the shape of potential function, while  $\gamma$  and  $f$  responsible for shape of potential function. All these functions were found out by using laboratory tests such as The Uniaxial Compression, The Uniaxial tension, Hydrostatic state of stress.

Table 1: CDP parameters (Chaudhari & Chakrabarti, 2012)

Parameter name	Value
Dilatation angle	36
Eccentricity	0.1
$f_{bo}/f_{co}$	1.16
K	0.667

DeMets et al., (1990) studied various nonlinearities included in the Reinforced Concrete structures static and dynamic analyses were examined. The studied nonlinearities were geometric and material (because of the steel and concrete nonlinear stress-strain connection). First, arbitrary Reinforced Concrete cross-sections nonlinear moment-curvature connection was numerically developed by steel and concrete nonlinear stress-strain connections. The significance of material and geometric nonlinearity was examined for a simple 2-storied frame under static vertical load.

## Methodology

For the purpose of studying effect of Earthquake on behavior of RCC structure a three storey single bay building frame has been modeled using Abaqus 6.13 and Dynamic load has been applied in the form of amplitude. The geometry of the model is as presented in the following figure.

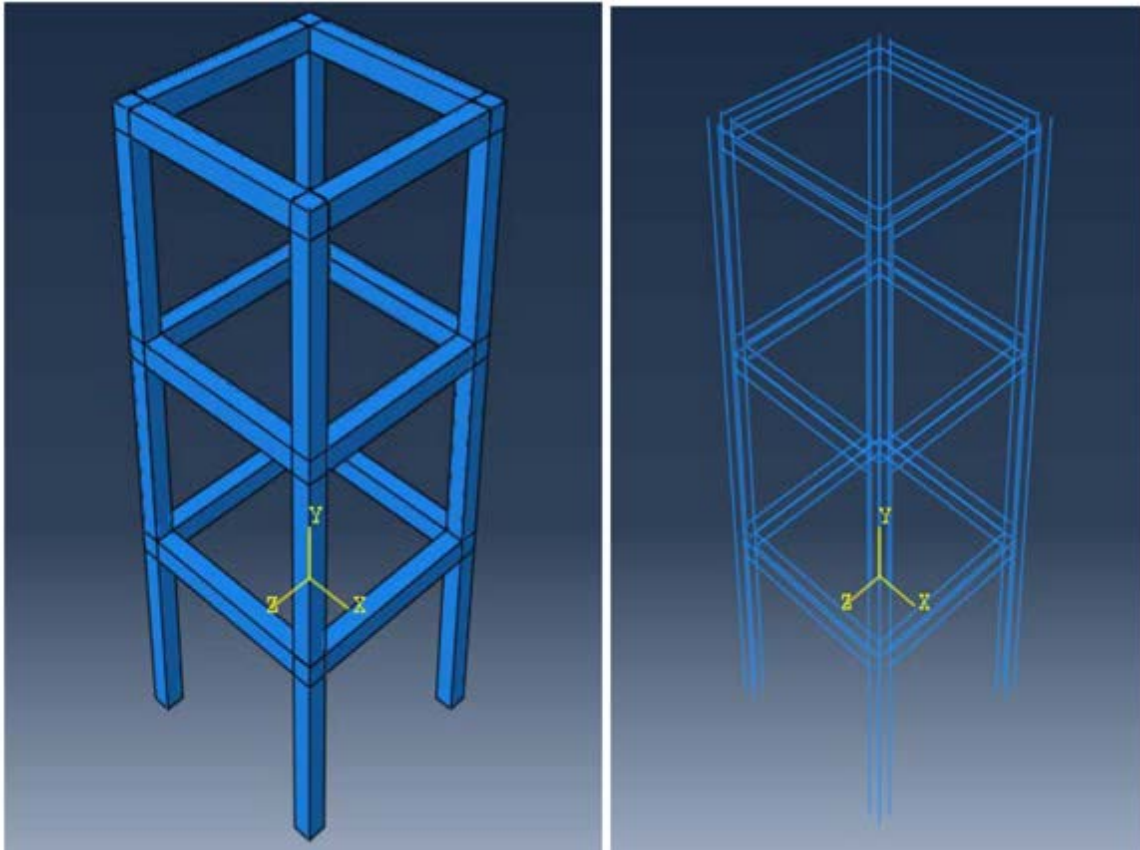

Figure 1: Three story building in Abaqus

A tie constrain has been defined between the surfaces of beam and column and embedded region has been used for defining the relationship between the Reinforcement and concrete. To define the tie constrain a partition plane has been defined on each column besides beam that are presented in figure 3.

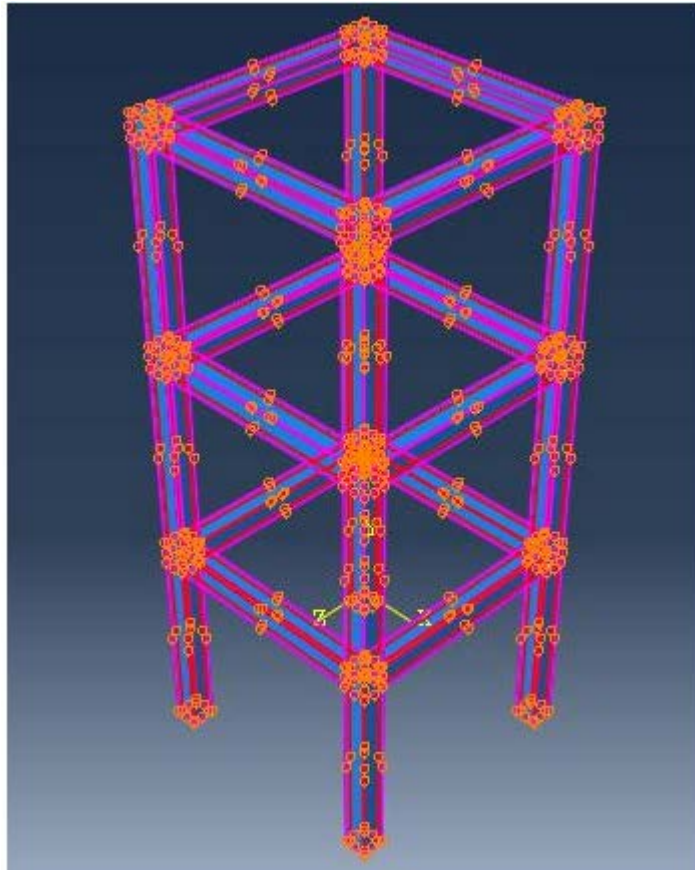

Figure 2 Embedded regions between concrete and reinforcement.

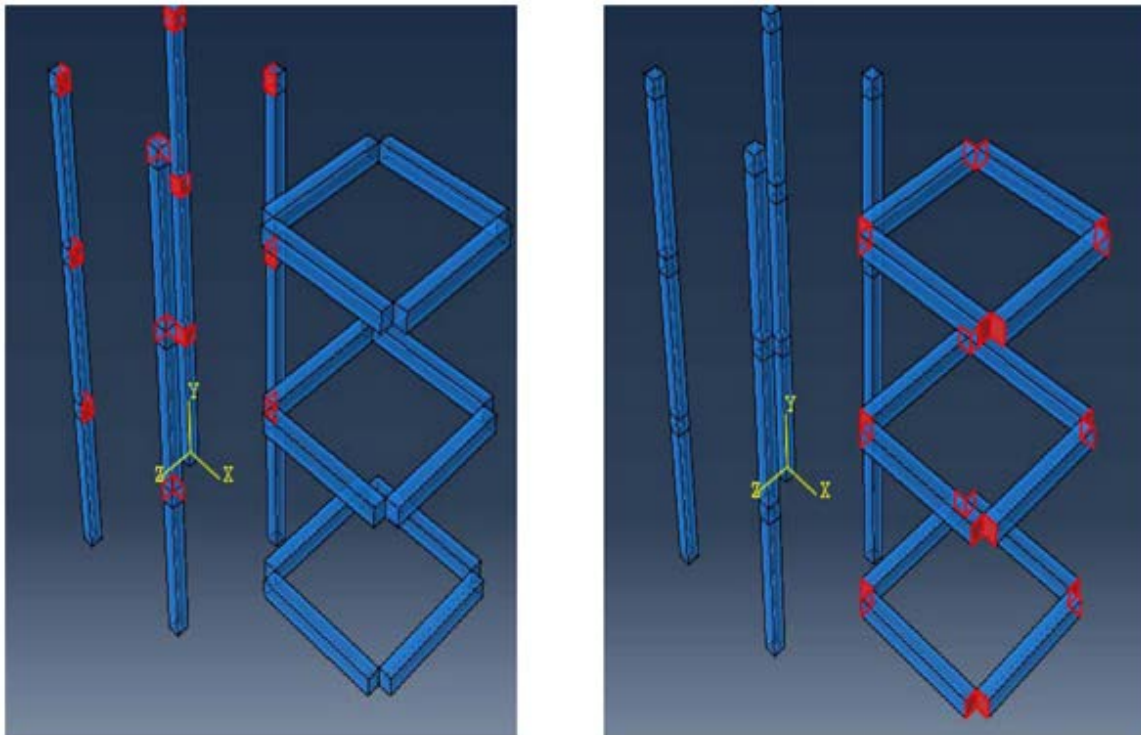
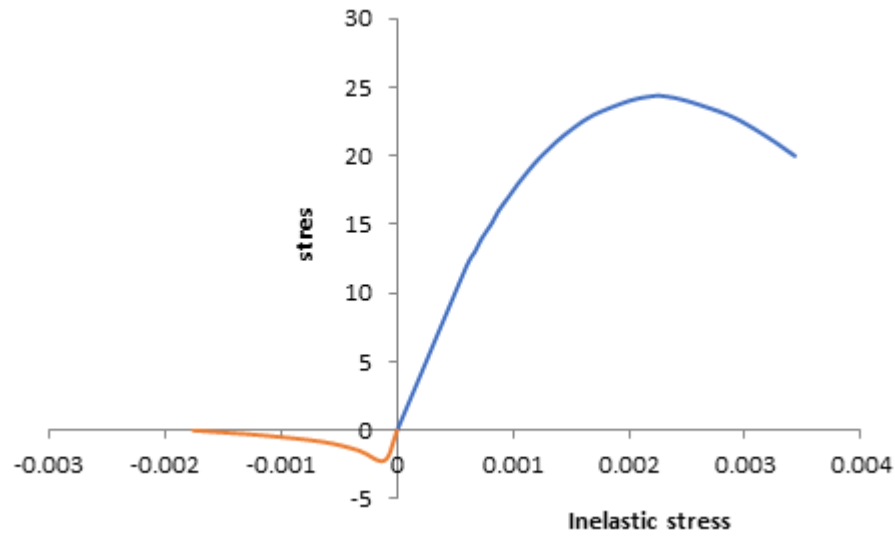

Figure 3 Beam and column lateral surfaces used for Tie region definition.

## Material

Material for beam and column is assumed to be a non-linear plastic concrete of Young's modulus 20 GPa and Poisson's ratio 0.18. A concrete-damaged plasticity was employed to define the plastic behaviors with parameter given by Tomasz Jankowiak table 1 and 2 (Chaudhari & Chakrabarti, 2012). The stress strain curve for concrete is determined using experimental data.



Parameter name	Value
Dilatation angle	36
Eccentricity	0.1
fbo/fco	1.16
K	0.667

The steel for the reinforcement is assumed to be linear elastic with Young's modulus  $2 \times 10^5 \text{ N/mm}^2$  and Poisson's ratio 0.3.

## Dynamic load

Load due to earthquake event is assumed to be in the form of acceleration data given below.

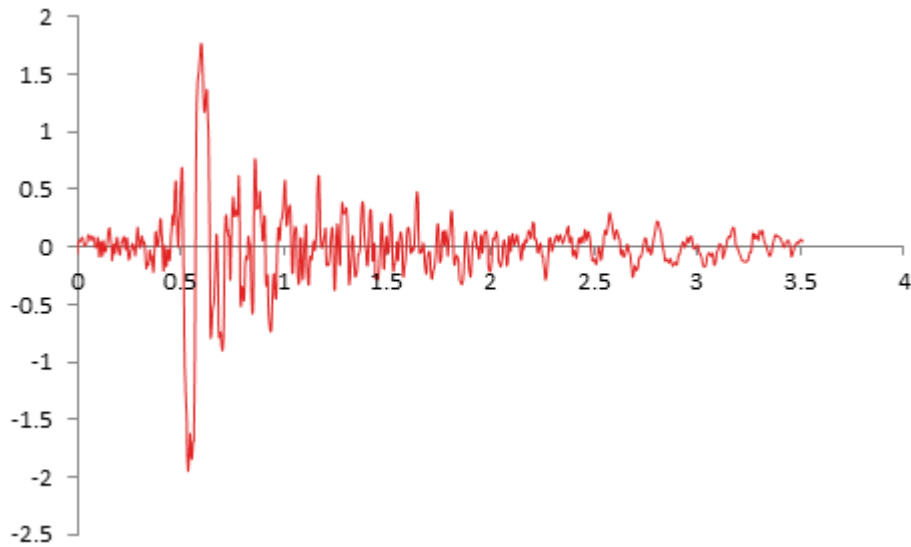

Earthquake with time line squeezed up by a factor of 10, used in Abaqus (Zaicenco et al., 1999).

### Meshing

A mesh sensitivity analysis has been done by performing a validation as per Joshua s Tayu (DeMets et al., 1990). Loads condition and modeling is kept as (DeMets et al., 1990) and analysis is done. load is increased at rate of 50kN and results of three point bending are plotted as bellow. In addition to that a conversion study is done by taking various mesh size i.e 200 mm 250 mm and 300 mm mesh size. From observation it can be concluded that, the deflection vs load comes close to the experimental results at mesh size 250 mm. hence here after modeling of frame is done by using 250 mm mesh size. The meshing of the frame is as shown in figure 6. An 8 noded continuous brick element (C3D8R) with reduced integration has been used for analysis (592 elements).

### Boundary condition

The end of the column at bottom was constrained in displacement in X and Y direction and second boundary condition has been applied in the form of acceleration as given in (DeMets et al., 1990).



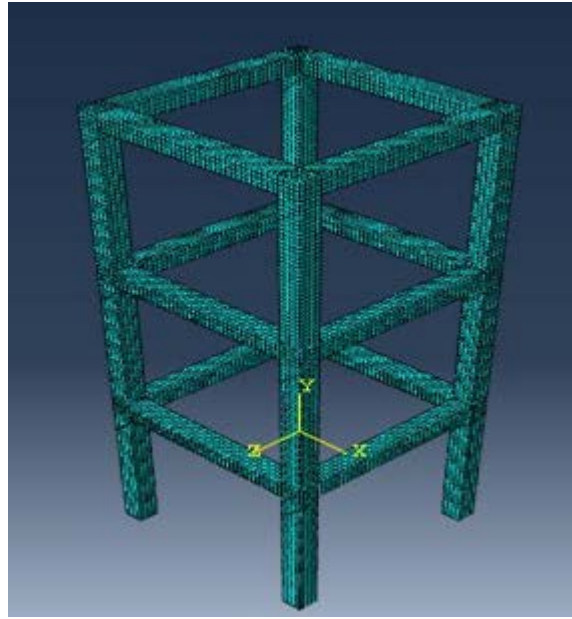

Figure 6

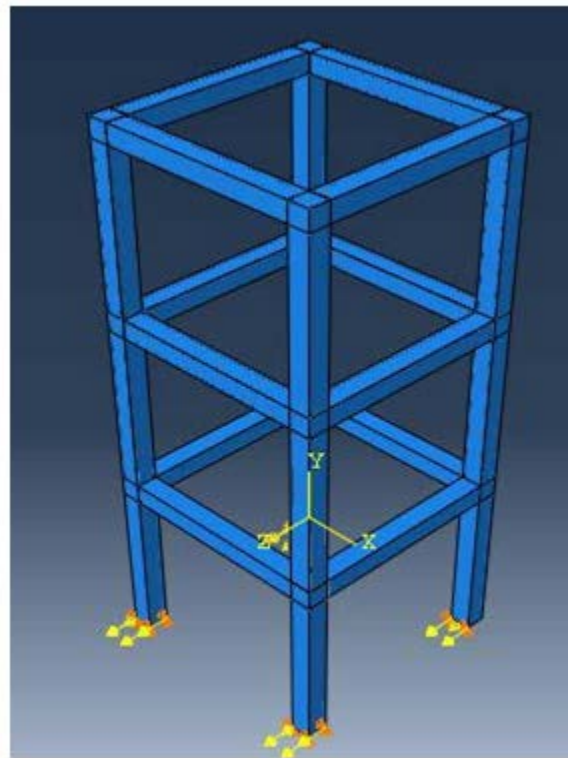
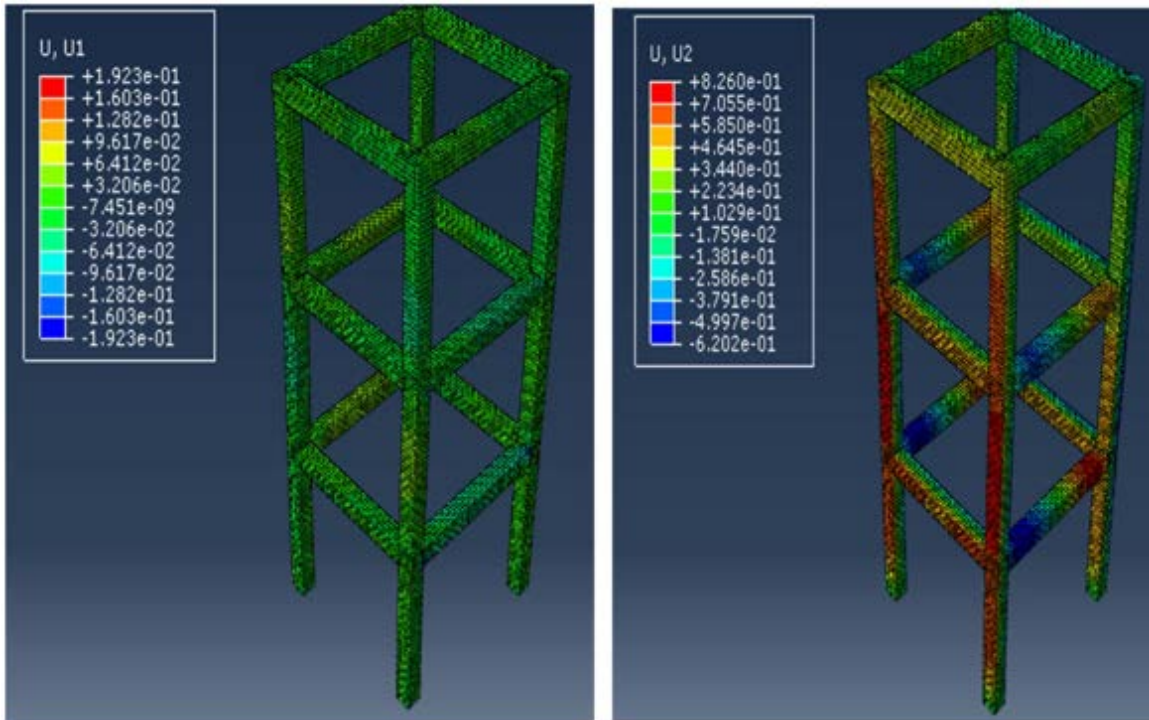

Figure 7 Acceleration boundary condition in Z direction.

## Results

Displacement in X, Y and Z direction has been determined which is found to be in agreement with the expected displacement in this type of structures.



Displacement in X Y and Z directions.

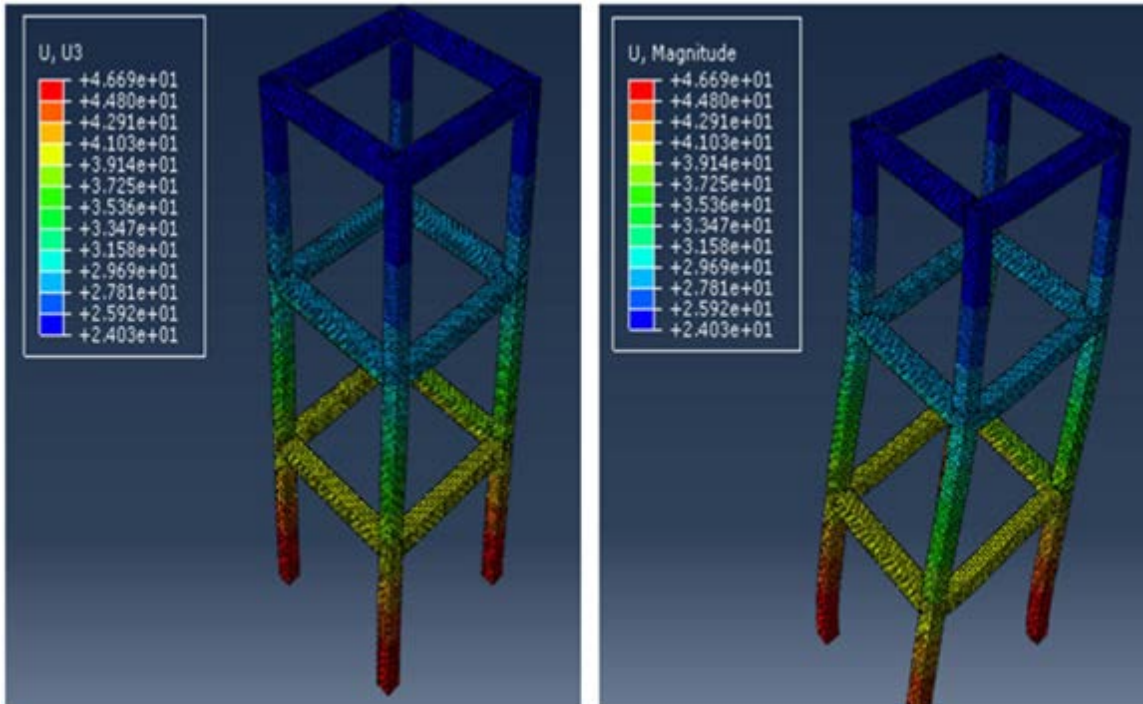

As the earthquake has been applied in N south direction i.e. in Z direction the maximum deflection 46.69 mm has been found in Z direction. This is deflection is more than the maximum deflection allowed for three story structure. Maximum and minimum shear stresses has been determined and reported as below.



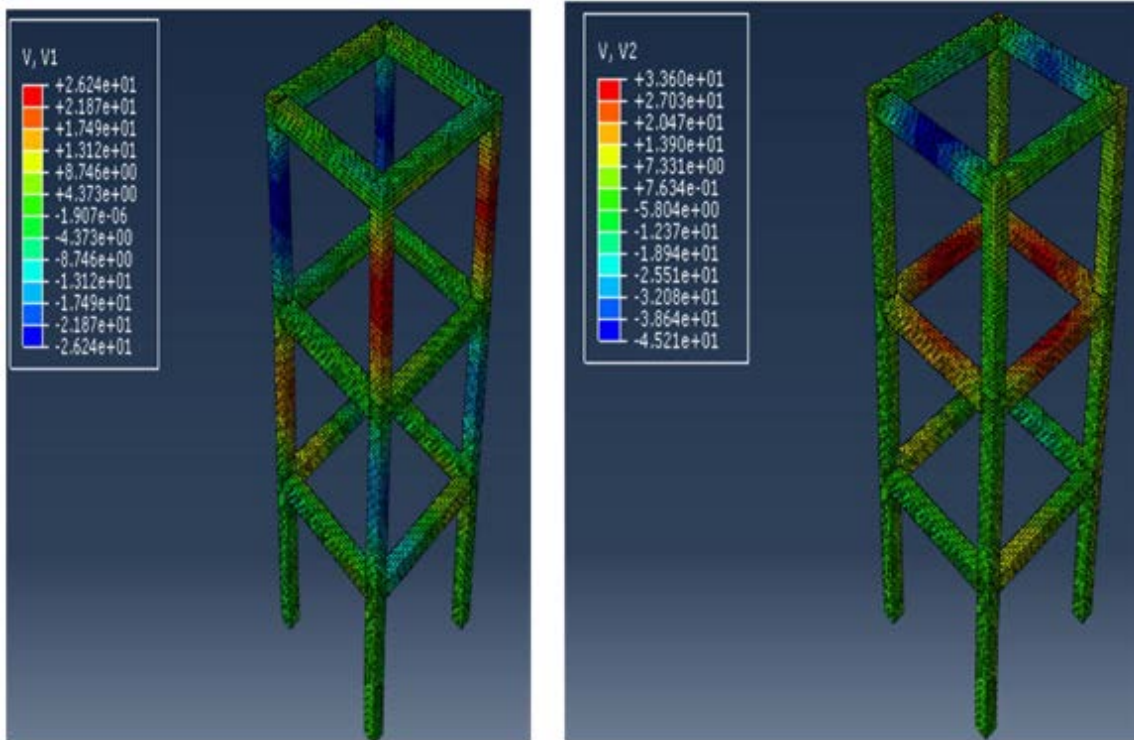

## Conclusion

According to the numerical outcomes, the next conclusions can be obtained:

- 1) The found results show that the structures' seismic response with few stories has considerable damage to the structure and rendered it failed due to high displacement of 47 mm
- 2) The constitutive material models assumed for underlying concrete has a major role in the seismic structural response. Moreover, it has to be noticed that there is a considerable difference amongst analysis results with linear elastic model and Concrete damaged Plasticity model condition that captures the important features of the concrete behavior with dynamic loading
- 3) Although the impacts of the earthquake on the deformations in the structure are insignificant compared with the fixed base support once the underlying concrete develops to be stiffer, the seismic motion frequency content has a main role in changing the seismic response. The dynamic response rapid increase is more obvious in resonance case, where the seismic ground motion frequency content is close to the fixed system frequency content. So, it is important to consider more realistic boundary condition than fixed system.

## References

- [1] ArRajehi, A., McClusky, S., Reilinger, R., Daoud, M., Alchalbi, A., Ergintav, S., ... & Haileab, B. (2010). Geodetic constraints on present-day motion of the Arabian Plate: Implications for Red Sea and Gulf of Aden rifting. *Tectonics*, 29(3).
- [2] Rodgers, A., Harris, D., Ruppert, S., Lewis, J. P., O'Boyle, J., Pasyanos, M., ... & Al-Gazo, A. (2003). A broadband seismic deployment in Jordan. *Seismological Research Letters*, 74(4), 374-381.

- [3] Samanta, A. K., & Tripathi, S. (2009). Effect of in-plane forces in beam-column junction of RC substitute frame in the linear regime. *ARPJ Journal of Engineering and Applied Sciences*, 4(10), 55-62.
- [4] Jankowiak, T., & Lodygowski, T. (2005). Identification of parameters of concrete damage plasticity constitutive model. *Foundations of civil and environmental engineering*, 6(1), 53-69.
- [5] Chaudhari, S. V., & Chakrabarti, M. A. (2012). Modeling of concrete for nonlinear analysis using finite element code ABAQUS. *International Journal of Computer Applications*, 44(7), 14-18.
- [6] Zaicenco, A., Lungu, D., Alkaz, V., & Cornea, T. (1999). Classification and evaluation of Vrancea earthquake records from republic of Moldova. In *Vrancea Earthquakes: Tectonics, Hazard and Risk Mitigation* (pp. 67-76). Springer, Dordrecht.
- [7] DeMets, C., Gordon, R. G., Argus, D. F., & Stein, S. (1990). Current plate motions. *Geophysical journal international*, 101(2), 425-478.